

AAV003-10E Current Sensor

Key Features

- For Low Current Detection
- On-Chip Current Strap for Precise Operation
- -80 mA to +80 mA Linear Range
- Sensitivity up to 2 mV/mA
- AC or DC Measurement
- Ultraminiature TDFN Package

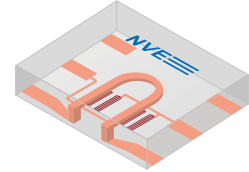

Description

The AAV003-10E is a high linearity, extremely low hysteresis GMR current sensor with an on-chip current strap. A GMR bridge sensor element close to the current strap senses the magnetic field created by the current. The GMR sensor element uses a unique, bipolar output, low hysteresis GMR material for excellent accuracy. The four terminals of the bridge sensor are available externally. The output terminals of the bridge provide a bipolar voltage signal proportional to the current through the strap.

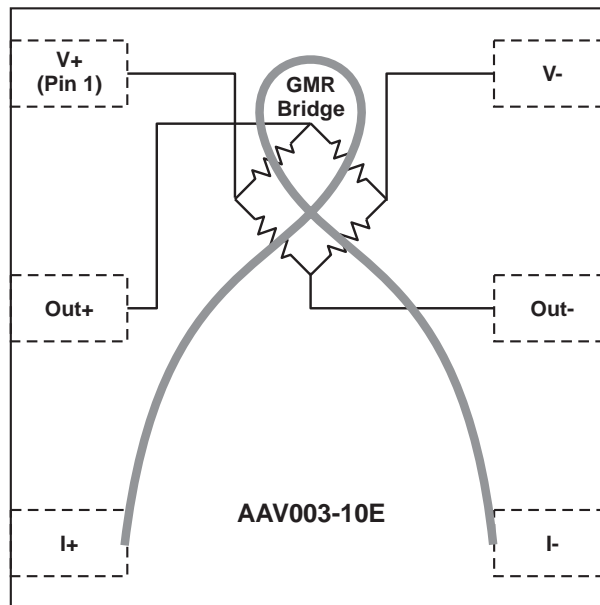

AAV003-10E Functional Diagram

Operation

A representative transfer curve is shown below:

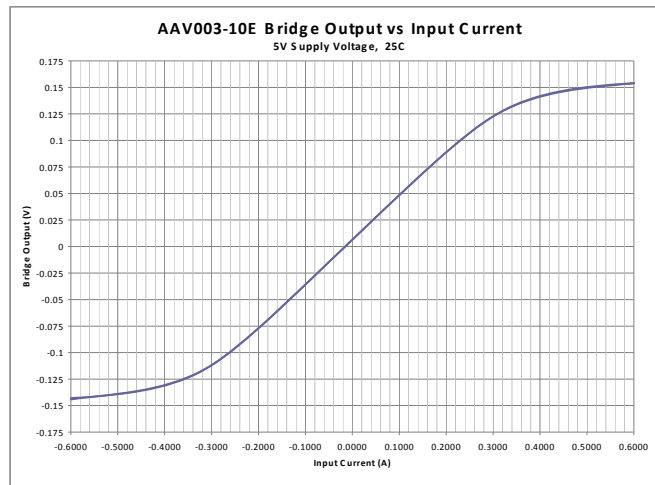

Operating Specifications:

| Parameter | Test Conditions | Min. | Typ. | Max. | Units |
|--|---|------|-------|------|------------------|
| Nominal Bridge Resistance | 25°C | 5500 | 7000 | 8500 | Ohms |
| Sensitivity | Operating; 5 V Supply, 25°C | 0.06 | 0.08 | 0.10 | mV/V-mA |
| Frequency Response | | 100 | | | KHz |
| Linear Range of Current Measurement | Operating; Full Voltage and Temperature Range | -80 | | 80 | mA |
| Output Linearity | Over Linear Current Range; Full Oper. Temperature Range | 99% | | | |
| Bridge Electrical Offset | 25°C | -4 | | +4 | mV/V |
| Offset Drift over Full Temperature Range | Zero Current | -1.0 | | 1.0 | mV/V |
| Bridge Supply Voltage | | | | 24 | [Volts] |
| Isolation Voltage | See Note 1 | 240 | | | V _{RMS} |
| On-Chip Current Strap Resistance | 25°C | 0.25 | | 0.35 | Ohms |
| On-Chip Current Strap Resistance Temperature Coefficient | | | +0.6 | | %/°C |
| Temperature Range of Operation | Operating | -40 | | 85 | °C |
| Bridge Resistance Temperature Coeff. | Operating | | +0.1 | | %/°C |
| Bridge TCOV ² | Operating | | -0.21 | | %/°C |

Notes:

- For isolation measurement, the sensor is considered a two terminal device:
I₊ and I₋ pins (pins 3 and 4) are shorted, and bridge pins (pins 1, 2, 5, and 6) are shorted.
- TCOV is the percent change in output signal over temperature, with a constant voltage source powering the part.

Absolute Maximum Ratings:

| Parameter | Min. | Typ. | Max. | Units |
|--------------------------|-----------|------|------|-------|
| Absolute Maximum Current | -600 | | 600 | mA |
| Bridge Supply Voltage | | | 30 | Volts |
| Storage Temperature | -40 | | 170 | °C |
| Ambient Magnetic Field | Unlimited | | | |

Note: Exceeding Absolute Maximum Ratings may cause permanent damage.

External Magnetic Fields and Hysteresis Effects

The AAV003-10E sensor elements are shielded to make them insensitive to external magnetic fields, however, shielding is not 100% effective, so external fields applied to the sensor should be avoided for the most repeatable, accurate operation.

When exposed to magnetic fields over 50 Oe (5 mT), the characteristic of the sensor can be disturbed, causing a hysteresis effect that will produce a non-linear response. A magnetic field of 50 Oe is a large field that should not be encountered during normal operation. However, in case the sensor is exposed to such a field, a degauss pulse train can be applied to the sensor to restore the original response. The sensor cannot be permanently damaged by any magnetic field, no matter how large and it can always be restored after exposure to a large field with a degauss signal.

This same effect can be observed when a large constant current (>200 mA) is applied to the on-chip current strap, or a smaller constant current (>100 mA) at high temperatures (>85°C). Again in these cases, correct operation of the sensor is restored with a degauss signal.

The degauss signal should consist of at least four current pulses of alternating polarity, with a pulse width of at least 50 μs and an initial current pulse of 600 mA:

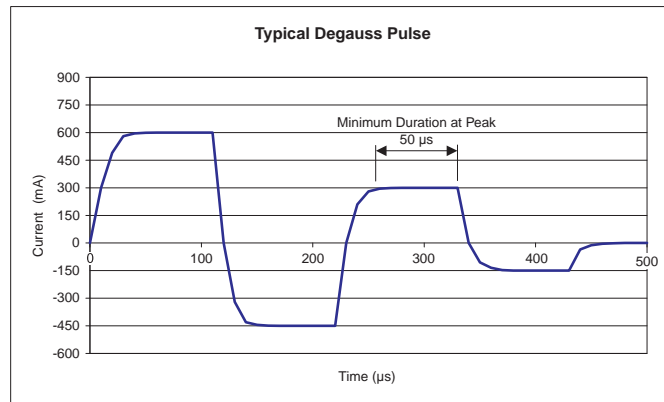

Temperature Characteristics

Typical output over temperature is shown in the graph below:

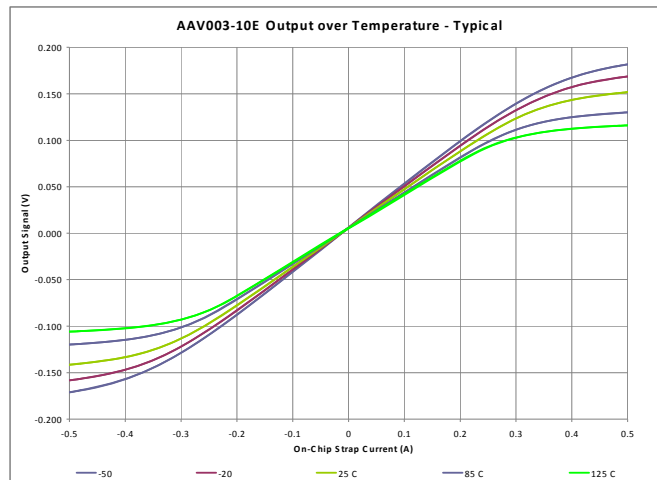

Pinout

The AAV003-10E pinout is as follows:

| Pin | Terminal | Description |
|-----|------------------|-------------------------------------|
| 1 | V ₊ | Supply Voltage |
| 2 | Out ₊ | Positive Differential Bridge Output |
| 3 | I ₊ | Current Terminal 1 |
| 4 | I ₋ | Current Terminal 2 |
| 5 | Out ₋ | Negative Differential Bridge Output |
| 6 | V ₋ | Ground |

Notes:

1. Pins are numbered counterclockwise around the package.
2. Current entering the chip via terminal I₊ and leaving the chip via terminal I₋ produces a positive bridge output.

Package Drawing – TDFN6 2.5 mm x 2.5 mm

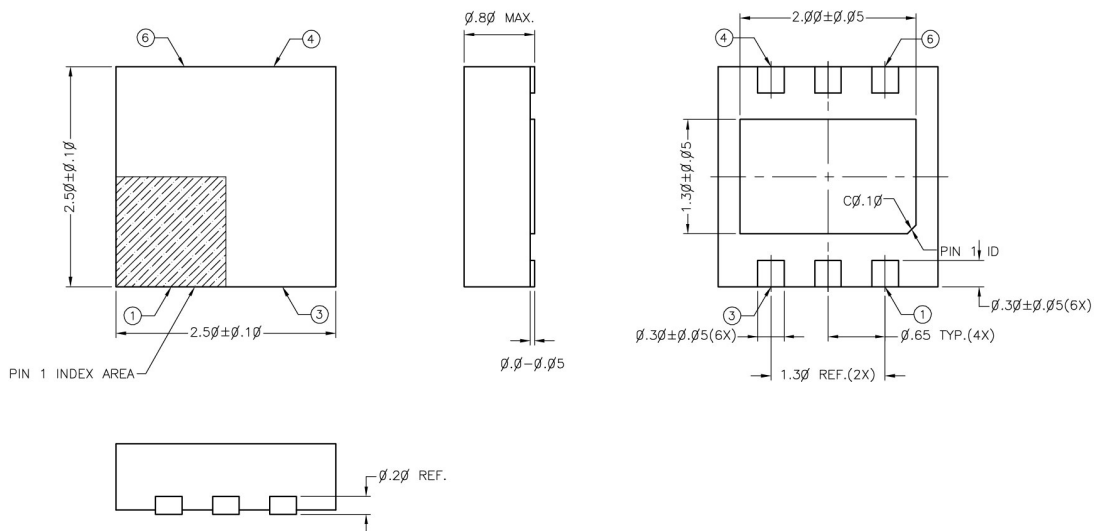

Notes:

- Dimensions in mm.
- TDFN6 package has thermal power dissipation of 320°C/Watt in free air.
- Attaching the package to a circuit board improves thermal performance, especially if the center pad is also soldered to the board.
- The center pad may be left floating or connected to ground.