

## Application Bulletin AB-10 Differential Line Receivers Using IL600-Series Isolators

A Differential Line Receiver is a device that translates differential voltage signals into standard logic signals. They are often integrated with differential voltage drivers to form transceivers for RS-485 and RS-422 applications. Isolation of these applications can be achieved in several ways. This application note examines the unique properties and capabilities of the IL600-Series as isolated differential line receivers.

### Conventional Isolated Line Receivers

There are two common methods to isolate differential signal networks such as RS-485 and RS-422. These either use three optocouplers and a discrete transceiver, or an integrated isolator/transceiver such as NVE's IL3585 or IL3522. Figure 1 shows a typical high-speed (more than 10 Mbps) two-node RS-485 network with transmission line terminations of 110 Ω and failsafe biasing resistors to ensure the R output is high when no drivers are active. This circuit has many great features: up to 32 devices can be attached to the network; it can drive up to 4,000 feet of twisted pair cable; and differential signals enable transient immunity of as much as 30 kV/μs. All of this comes with 2.5 kV<sub>rms</sub> input-to-output isolation.

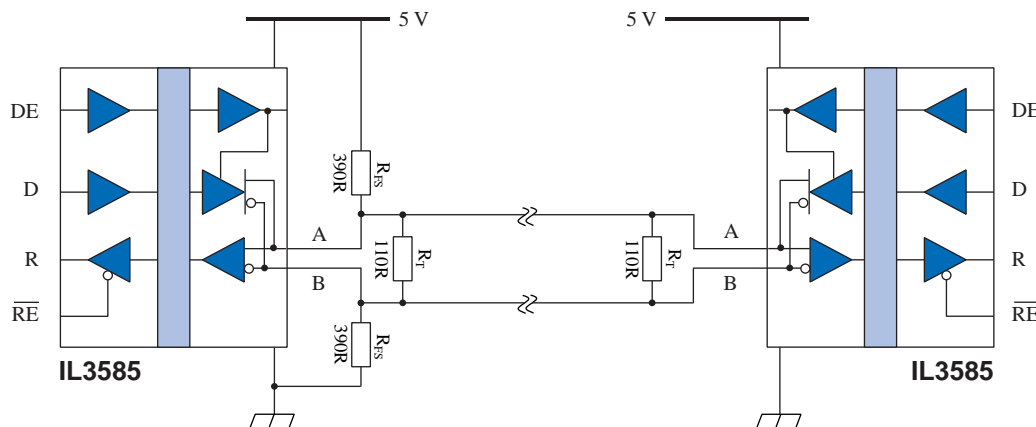

**Fig 1. Full-featured Isolated RS-485 Using IL3585 Isolated Transceiver**

So what's the catch? The only real drawback of the conventional approach is cost. You will typically pay about \$5 per isolated node, and much more if volumes are less than 5,000 pieces per year. That can be particularly frustrating when unidirectional communication is all that is required. In that case, each isolated transceiver node is configured in "listen" mode, meaning only one third of the isolated transceiver capability is used by the application.

Enter NVE's elegant isolators as line receivers. Figure 2 shows a "Listen Only" application using RS-485 where a transceiver provides the master bus signal, but the receiver on the other side of the line is an IL610.

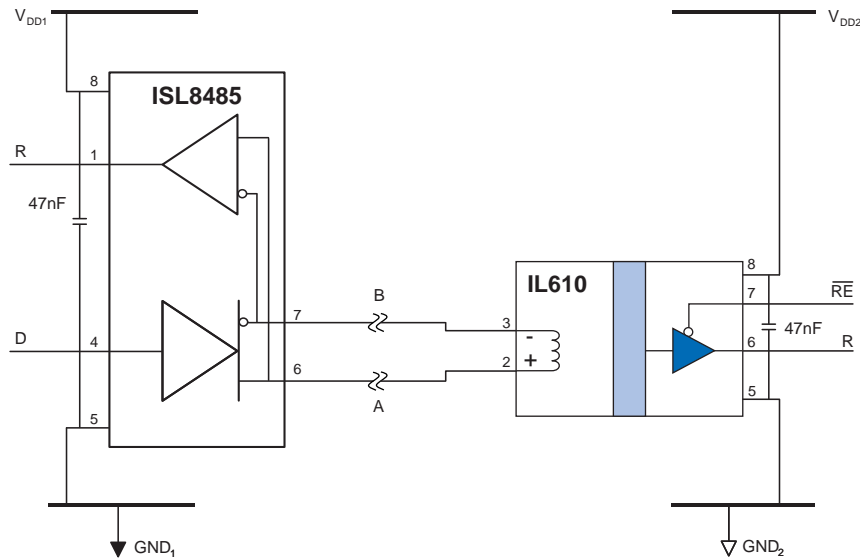

**Fig 2. An IL610 Used as a Simple Isolated RS-485 Receiver**

Let's look at the characteristics of this circuit compared to those of Figure 1. The first thing to note is the absence of external resistors. The failsafe bias resistors of Figure 1 are necessary to ensure the high impedance bus is biased with at least +250 mV between the A and B lines to guarantee the state of the R output when no drivers are active on the bus. Without this control, the R output can "chatter," causing transmission failures. The penalty for the inclusion of these resistors is at least 7 mA of additional supply current. The IL610 is guaranteed to switch to the high state when the coil input current is less than 500  $\mu$ A. When the RS-485 bus is in high-impedance mode, the current through the coil approaches zero so the output will automatically go high, eliminating the need for external failsafe biasing and saving that 7 mA of bias current. In addition, there is no need for line termination resistors in most IL610 line receiver applications below a data rate of 10 Mbps. In a conventional RS-485 network pair, the bus impedance is the parallel combination of the two receivers plus the connecting cable, or approximately  $(6k - j110)\Omega$ , where the real component is due to the parallel combination of the two receiver inputs and the complex component is due to the reactance of the cable at  $f = 100$  kHz. In the IL610 example, the line resistance is dictated by the IL610's low resistance coil. The coil resistance is approximately 85  $\Omega$ , so signal reflections are close to their minimum value without external terminators. If the bus length is long and data rates are high, line terminations may still be needed to reduce reflections to an absolute minimum, but the IL610 will function well with data rates as high as 20 Mbps and twisted-pair cable lengths of 100 feet without terminations. That's comparable to the performance of any conventional isolated transceiver.

The unique passive inputs of IL600-Series Isolators allow direct interconnection of differential networks without the need to supply power to the input side of the isolated network. The *signal* supplies the current to initiate data transfer, eliminating one layer of DC/DC converters or other power supplies from the isolated node. Up to eight isolated receivers can be accommodated on the network if the master signal comes from a typical RS-485/RS-422 driver. Current limiting resistors should be used to prevent overload of the driver circuit. Table 1 shows the value of resistor recommended for the number of nodes allowed:

Number of Nodes	Current Limit Resistors ( $\Omega$ )
1	None
2	17
3	22
4	27
5	27
6	27
7	30
8	30

**Table 1. Recommended Resistor for Various Numbers of Nodes**

Figure 3 shows a two-receiver RS-485 network using IL610s, while Figure 4 shows a similar RS-422 network. Note the placement of current limiting resistors on both lines for better dynamic signal balance:

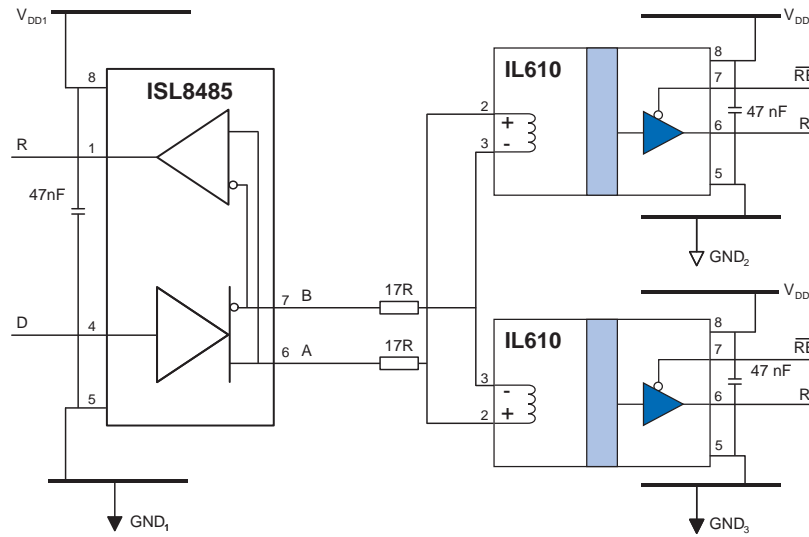

**Figure 3. RS-485 Network Using IL610s**

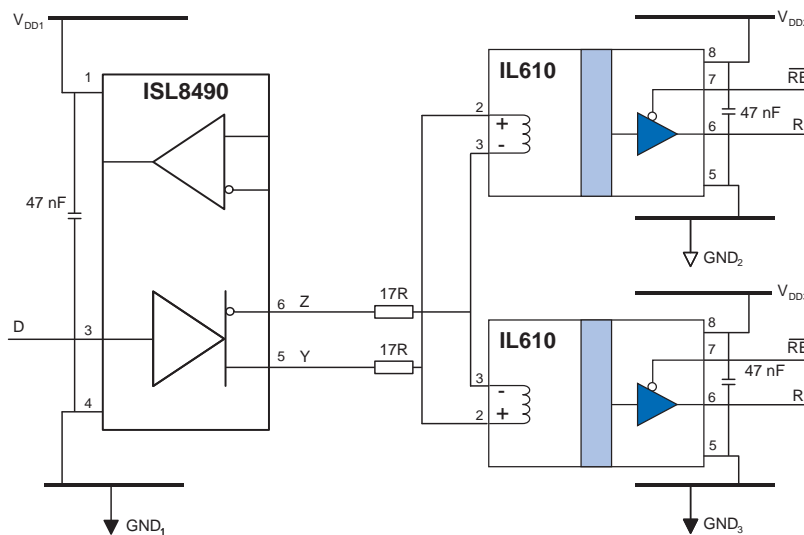

**Figure 4. RS-422 Network Using IL610s**

## Reducing Power Dissipation in RS-422/RS-485 Networks

An interesting property of the *current mode* switching technique employed in the IL600-Series is the ability to reduce power dissipation in the network without compromising other network parameters. In a conventional RS-422 network, for instance, the only way to eliminate the heavy load currents drawn by the driver circuits is to eliminate termination and failsafe bias resistors. That obviously compromises network speed and line length and can lead to chatter on the R output when the bus is in “listen” mode. Figure 5 shows an unterminated RS-485 node pair and a 477 Ω resistor in parallel with a bypass capacitor of 32 pF (known here as the **Boost Capacitor**) on the “A” line. The resistor limits DC current to approximately one-eighth of the circuit in Figure 3 while the capacitor allows instantaneous current proportional to edge speeds ( $C \frac{dV}{dt}$ ) to pass to the receivers. This is rather like the dynamic termination option recommended in some conventional RS-422 applications, but when used with IL600s it has the additional advantage of being intrinsically failsafe. Maximum network speeds and line lengths will be lower using this method than with those of Figures 3 and 4, as will dynamic specifications such as transient immunity, but speeds of 20 Mbps are still possible with lower network node counts and shorter cable lengths.

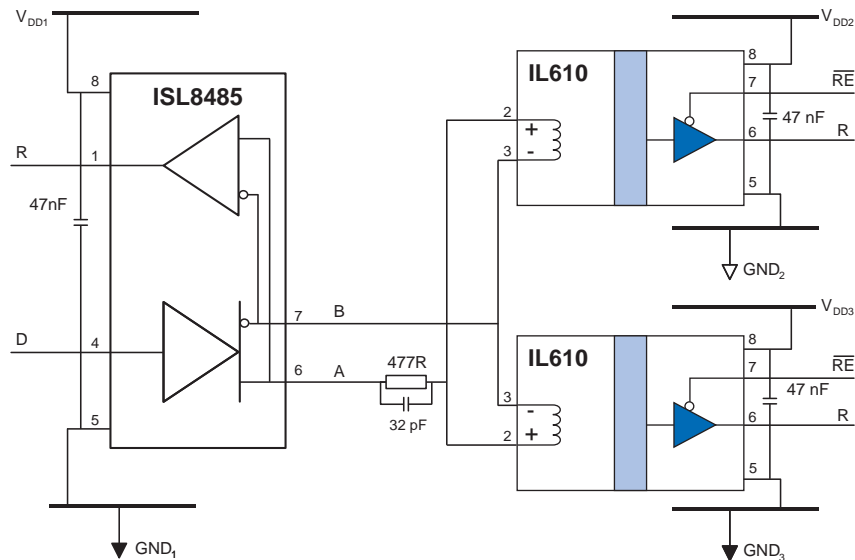

**Figure 5. Reduced Power Dissipation RS-485 Using IL610s With Boost Capacitors**

### Boost Capacitor Selection

The capacitor value and rise and fall times of the RS-485/RS-422 driver dictate how much extra current is delivered to the input coil of the line receiver. For high-speed transceivers (driver rise and fall time less than approximately 10 ns, such as the example in Figure 5), a 32 pF capacitor is recommended. Figure 6 is a guide for slower signals. The capacitor value is not critical and can vary  $\pm 50\%$  with little noticeable difference in device performance, but care should be taken to limit instantaneous boost current to approximately  $\pm 30$  mA. Check your numbers with  $I_{\text{Boost}} = C \frac{dV}{dt}$ . Instantaneous currents of more than  $\pm 100$  mA could destroy the input coil.

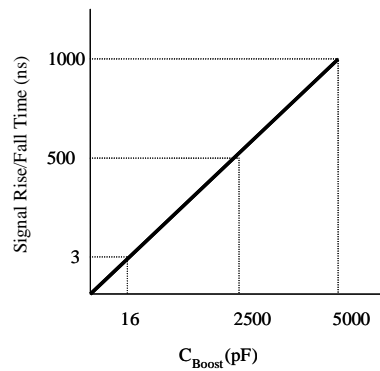
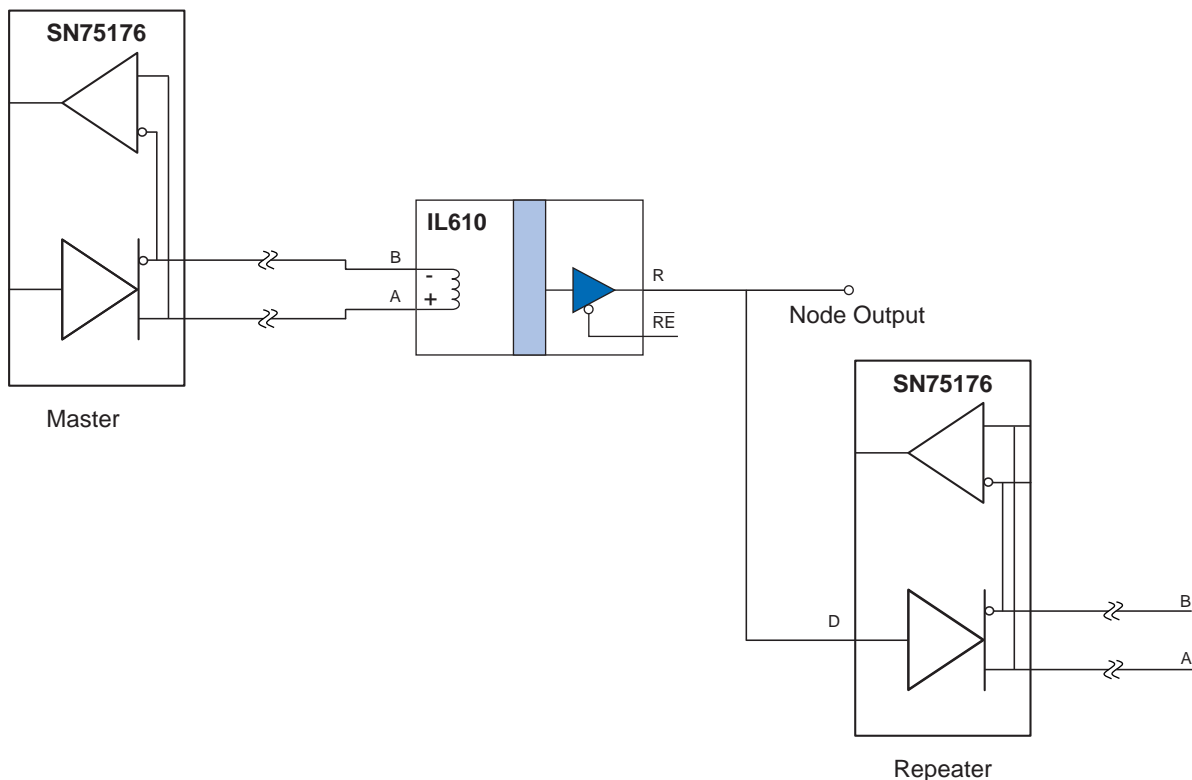

**Figure 6. Boost capacitor selector**

**Extending the range of RS-422 Networks**

Simple, low cost, isolated repeater systems can be made with an RS-422 transmitter/receiver pair (or an RS-485 transceiver in *drive mode*) and an IL610. Repeaters can extend the useful cable length and node count indefinitely, provided the network controller can tolerate the additional propagation delays.

Figure 7 shows an example of an RS-422 repeater network. In this mode, the IL610 can be used in unterminated mode for maximum signal integrity, or the boost capacitor / in line current limit resistor may be employed to reduce power dissipation.



**Figure 7. RS-422 Repeater Configuration Using IL610s**

## General Applications

Applications for isolated differential line receiver circuits include board-to-board communications and other short-distance (less than 100 feet) interfaces where more expensive “full featured” transceivers are overkill. The IL600-Series provides 2.5 kV<sub>RMS</sub> isolation (one minute), and 20 kV/μs transient immunity. The IL610-1 MSOP Isolator is a unique product for space-critical boards.

## Bus Standards

A final word on data transmission standards. The circuits discussed here are not EIA-422/485 compliant because they require higher differential voltages than the EIA standard input sensitivity specifications allow. The maximum number of eight “Unit Loads” allows DC compliance with any EIA-422/485 specified device, but care should be taken to ensure cable loading does not reduce signals below the required thresholds. There should be sufficient signal voltage to force at least ±5 mA through the 85 Ω receiver coil on each node.

## Coil Current Limitations

Reliability tests show that dynamic coil currents of ±75mA, at frequencies above 0.1 Hz have no detrimental effect on the mechanical integrity of the integrated coil in IL600-Series Isolators. Such limitations are caused by excessive local heating ( $I_{\text{coil}}^2 R_{\text{coil}}$ ) and particle migration in micro-machined structures. At operating frequencies below 0.1 Hz, and especially at DC current levels, coil current magnitude should not be allowed to exceed |20|mA. Accelerated testing shows the coil could “open” after approximately 2,400 hours with a DC current flow of initially 25 mA at an ambient temperature of 55°C. In all differential applications, the preferred idle mode for the IL600 Series is with a differential voltage of approximately zero. In RS-485/RS-422 applications this is easily achieved by ensuring the bus idles with no drivers enabled.