

**Application Bulletin AB-12**  
*IsoLoop Isolators for High-Efficiency Power Control*

**Introduction**

The increasing use of power MOSFETs to control load power in motor controllers, power converters and amplifiers has spawned many imaginative engineering solutions to the inefficiencies the device brings to these applications. This application briefly discusses some of those solutions and shows how IsoLoop<sup>®</sup> Isolators can improve many aspects of power transistor control.

The basic design problem is how to drive the MOSFET connected to the highest voltage rail into full enhancement (minimum voltage across the device). Anything less than full enhancement leads to power dissipation losses in the transistor, but in order to achieve that, the Gate terminal has to be biased 10 V to 12 V higher than the Source terminal. The art in the design of the gate driver is in developing a control voltage 10 V higher than what is usually the highest voltage present in the application.

**The Power MOSFET**

The power MOSFET is a vertical structure, from the double diffused DMOS family. The vertical structure enables expansion both vertically and horizontally to accommodate higher voltages and higher switching currents respectively. Intrinsic to the structure is a diode connecting Drain to Source. The diode means current flow can only be blocked in one direction, but as we'll see later, that drawback can be used to good effect in *Synchronous Rectifier* applications.

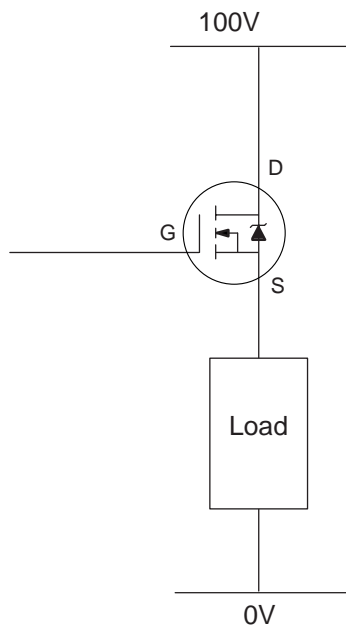

**Fig. 1. The Basic Power MOSFET and the High-Side Configuration**

## MOSFET Operation

The same operating principles of all Field Effect Transistors apply to the Power MOSFET. To switch the device on, a voltage is applied to the isolated gate and the resultant electric field causes a change in material polarity such that current flows from Drain to Source. Enhancement mode (normally off) MOSFETS are always used in power applications and while both P and N type devices are used, N-channel devices are by far the most common. For an N-channel MOSFET, the electric field derived from the Gate voltage causes the Drain P-channel to change to N-type removing the blocking diode and allowing current to flow.

In theory, the ideal MOSFET is a voltage-controlled device with no current flowing into the gate. DC current flow into the gate is limited to the leakage current of the gate input (typically less than 100 nA), and is of no consequence in power applications. During switching, however, instantaneous current flows into the gate because of the significant capacitance of the vertical DMOS structure and the very fast switching transients required in the application. The bigger the MOSFET and the faster the switching, the larger the current and the longer it will flow. The switching losses in a large MOSFET can be considerable, requiring the designer to use larger heat sinks than the On-Resistance of the device dictates, and reducing the overall efficiency of the drive. The solution lies in the selection of gate driver and the isolation technique used to create the gate voltage for the high-side switch.

NVE offers a range of high-speed single and dual channel isolators that have ideal switching characteristics and can be used to replace optocouplers in the gate driver. Typical pulse width distortion of only 1 ns minimizes transistor dead time and maximizes system efficiency, while ultra-small packages (including two-channel MSOP-8s) allow the designer to squeeze more and more into a smaller board area.

## High Side Driver Techniques

There are two main techniques in common use to drive MOSFET gates in full and half bridge configurations: the floating gate drive supply, and the bootstrapped gate drive. Both require level shifting of the input signal reference to the value of the high side supply. In a bootstrapped gate driver, the level-shift function is usually integrated into the chip while the floating gate driver has traditionally used an optocoupler. Table 1 shows several IsoLoop devices that are well suited for floating drive level shifting:

IsoLoop Device	Channels	Package	Input
IL710	Single Channel	PDIP, SOIC, MSOP	Digital
IL711	Dual Channel	PDIP, SOIC, MSOP	Digital
IL610	Single Channel	PDIP, SOIC, MSOP	Passive
IL611	Dual Channel	PDIP, SOIC, MSOP	Passive
IL613	Triple Channel	SOIC	Passive

**Table 1. IsoLoop Isolators for floating drive level shifting.**

The basic configuration for a typical high side drive using a floating supply is shown in Figure 2:

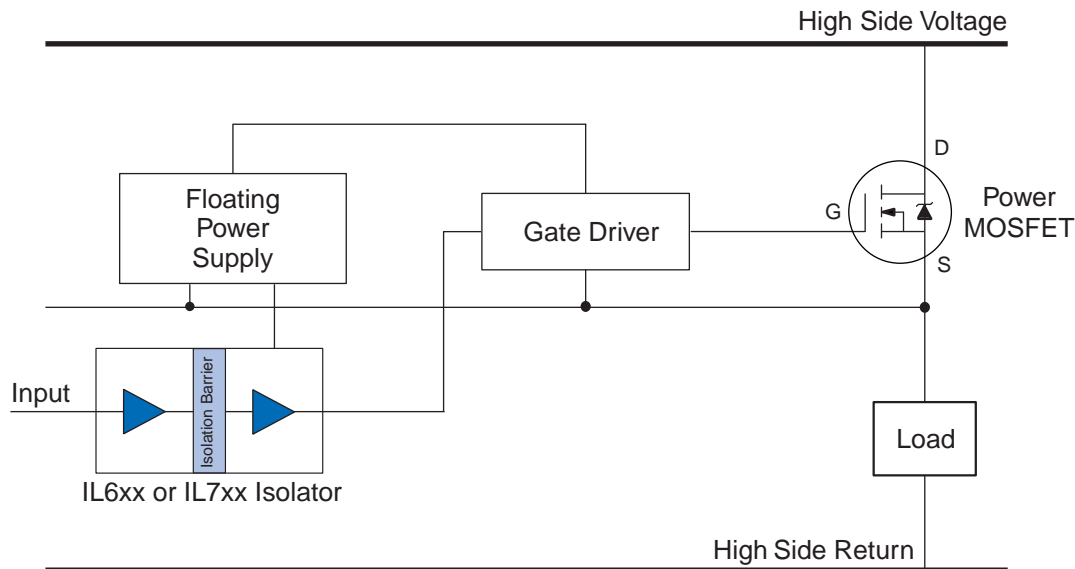

**Fig. 2. Basic High Side Gate Driver**

IsoLoop devices have many advantages over optocouplers as level shifters in isolated gate drivers, but perhaps most important is the advantage of the level shifted gate drive technique itself over the lower cost bootstrapped technique. In the bootstrapped version, the gate is pulsed by current provided from the bootstrap capacitor. The capacitor must be refreshed every cycle, so the maximum drive frequency and the size (power) of the MOSFET itself limit the use of bootstrapped devices. The fully isolated option provides constantly available voltage and current to drive the gate, improving noise, reliability, and versatility. Compared to optocouplers, IsoLoop isolators improve  $dV/dt$  transient immunity from less than  $5 \text{ kV}/\mu\text{s}$  to  $30 \text{ kV}/\mu\text{s}$ , and pulse width distortion is reduced from at best  $15 \text{ ns}$  to  $1 \text{ ns}$  with attendant propagation delays of  $8 \text{ ns}$ . All of these specifications help to minimize transient shoot through and power transistor dead time compared to optocoupler designs.

### Synchronous Rectifiers

Synchronous rectifiers solve the problem of the diode drop in traditional power supply rectification circuits. Each diode used in a typical half bridge full wave rectifier requires between  $0.6 \text{ V}$  and  $0.7 \text{ V}$  to fully turn on. In low voltage applications such as  $3.3 \text{ V}$  and  $2.7 \text{ V}$  microprocessor supplies, the long periods of zero current flow create very inefficient power supplies. Power MOSFETs are used to allow the designer to pulse the gate on at the zero volt crossovers, eliminating the diode drop and greatly improving the efficiency ratings in all power supplies, but especially the low voltage types. In addition, the intrinsic diode in the MOSFET blocks current flow in the opposite direction without external diodes.

In today's high efficiency telecom, industrial and automotive power supplies, microcontrollers with on-chip A/D converters, and PWM generators are used to drive synchronous rectifier circuits with incredible flexibility. Very difficult hardware tasks such as soft start-up are now easily programmed into these versatile devices. The microcontrollers can be found on either secondary or primary sides of the power supply depending on specific application design goals. In either case isolating the synchronous drive or PWM signals using an IsoLoop device instead of an optocoupler brings all the advantages listed in the gate driver section of this bulletin to versatile power supply design.

Figure 3 shows a typical primary-side controller using the IL711 to drive synchronous rectification signals from primary to secondary. A secondary-side power supply control setup would use an IL710 to drive the PWM control signal across the isolation barrier to the primary-side controller.

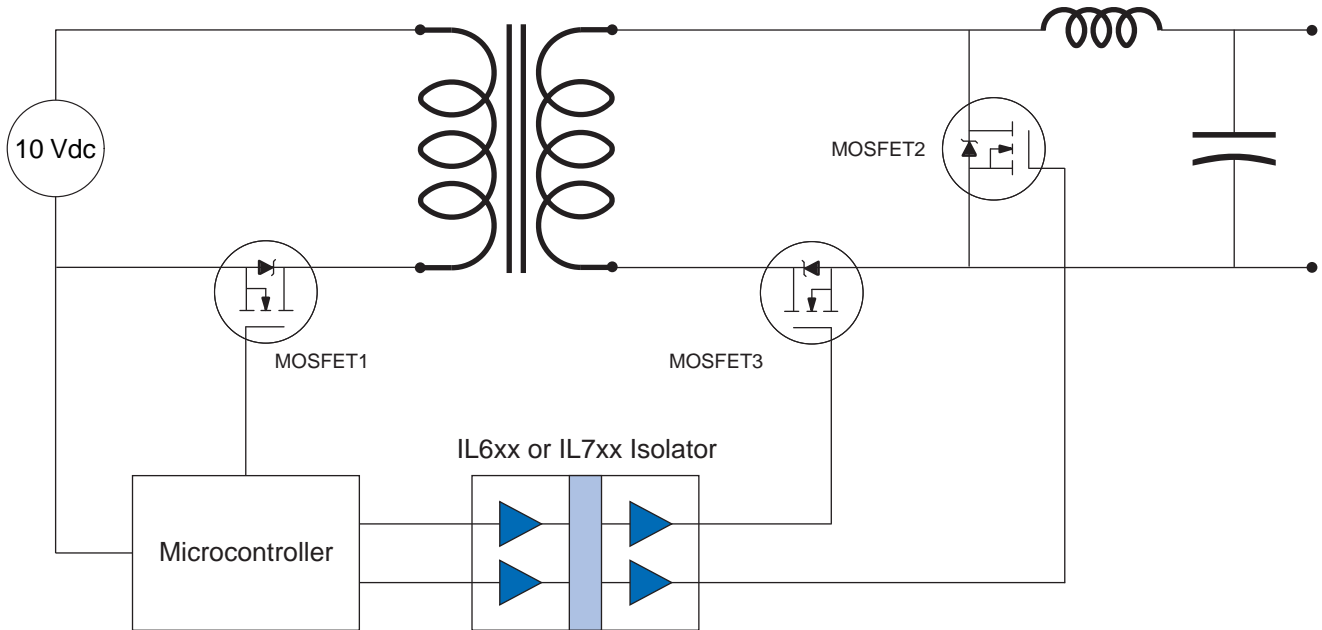

**Fig. 3. Intelligent DC-DC Converter With Synchronous Rectification**

*ISB-AP-12; rev. April 2008*