

Data Sheet No: E28001

Version: V2

Date: 2024/05/13



APLR1000

Non-Inductive High Energy Anti-Pulse Resistor

Resistance	20Ω~10KΩ
Tolerance	±5.0%
TCR	±200ppm/°C
Peak Energy	1000J

Applications

Automotive Electronics
Precision Power Supply
Medical Equipment
High Voltage Power Supply

**Better Solution for Sustainable
High End Manufacturing**



Small Size, High Humidity Resistance, High Reliability Single Pulse Energy Up to 1000J

Introduction

To produce a high-performance anti-pulse resistor, in addition to considering its anti-pulse capability, it is also necessary to balance parameters such as TCR, moisture resistance, long-term stability, and failure mode. High energy wire wound resistors have good ant-pulse ability, but relatively high inductance and poor reliability. Solid ceramic resistors are naturally non-inductive and have strong ant-pulse ability, but have a high TCR (-800ppm/°C), poor long-term stability ($\pm 5\%$), and poor moisture resistance ($\pm 5\%$). APLR1000 series high-energy anti-pulse resistor utilizes specialized resistive materials independently developed by C&B Electronics, which can withstand single pulse energy of up to 1000J, and overcome the shortcomings of wire wound resistors and solid ceramic resistors. APLR1000 features in non-inductance, low TCR, strong moisture resistance, and good long-term stability.

APLR1000 series, from raw materials, core equipment, to core processes, achieves independent and controllable production, stable quality, and timely delivery. If the standard specifications cannot meet your needs, please contact our sales for consultation. Resi is committed to providing the best precision resistor solutions to meet the needs of customers in medical equipment, automotive electronics, instrumentation, high-voltage power supply and other fields.



Electrical Parameters

Series	Resistance	Rated Power (+70°C)	Peak Energy ¹	Peak Voltage ²	Operating Temperature	TCR ppm/°C(+20°C Ref)	Tolerance %
APLR1000	20Ω	6W	1000J	400V	Epoxy Coating: -55°C~+125°C Silicone Coating: -55°C~+175°C	±200(-55°C~+125°C)	±5.0 ±10.0
APLR1000	50Ω	6W	1000J	700V	Epoxy Coating: -55°C~+125°C Silicone Coating: -55°C~+175°C	±200(-55°C~+125°C)	±5.0 ±10.0
APLR1000	100Ω	6W	1000J	1000V	Epoxy Coating: -55°C~+125°C Silicone Coating: -55°C~+175°C	±200(-55°C~+125°C)	±5.0 ±10.0
APLR1000	150Ω	6W	1000J	1500V	Epoxy Coating: -55°C~+125°C Silicone Coating: -55°C~+175°C	±200(-55°C~+125°C)	±5.0 ±10.0
APLR1000	200Ω	6W	1000J	1900V	Epoxy Coating: -55°C~+125°C Silicone Coating: -55°C~+175°C	±200(-55°C~+125°C)	±5.0 ±10.0
APLR1000	300Ω	6W	1000J	2500V	Epoxy Coating: -55°C~+125°C Silicone Coating: -55°C~+175°C	±200(-55°C~+125°C)	±5.0 ±10.0
APLR1000	500Ω	6W	1000J	3500V	Epoxy Coating: -55°C~+125°C Silicone Coating: -55°C~+175°C	±200(-55°C~+125°C)	±5.0 ±10.0
APLR1000	1KΩ	6W	1000J	5000V	Epoxy Coating: -55°C~+125°C Silicone Coating: -55°C~+175°C	±200(-55°C~+125°C)	±5.0 ±10.0
APLR1000	2KΩ	6W	1000J	5000V	Epoxy Coating: -55°C~+125°C Silicone Coating: -55°C~+175°C	±200(-55°C~+125°C)	±5.0 ±10.0
APLR1000	3.3KΩ	6W	1000J	5000V	Epoxy Coating: -55°C~+125°C Silicone Coating: -55°C~+175°C	±200(-55°C~+125°C)	±5.0 ±10.0
APLR1000	4.7KΩ	6W	1000J	5000V	Epoxy Coating: -55°C~+125°C Silicone Coating: -55°C~+175°C	±200(-55°C~+125°C)	±5.0 ±10.0
APLR1000	10KΩ	6W	1000J	5000V	Epoxy Coating: -55°C~+125°C Silicone Coating: -55°C~+175°C	±200(-55°C~+125°C)	±5.0 ±10.0

1. 1000J is the maximum peak energy that APLR1000 can withstand under single pulse conditions, and the average power of continuous pulses cannot exceed 6W.

There may be differences in peak energy under different operating conditions, such as higher ambient temperatures. It is recommended to derate at extreme operating conditions.

2. Peak voltage is related to peak energy. Please contact us for confirmation of higher peak voltage.

Dimensions

Unit:mm

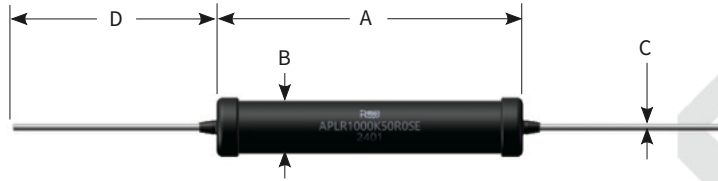

Series	Resistance	A	B	C	D	Packaging	Quantity	Net Weight
APLR1000	20Ω~10KΩ	52±1.5	8.5±1	1.0±0.1	36±3	Bulk	25pcs	10g±2g

Part Number Information

Example: APLR1000K50R0SE (APLR1000 ±10% 50Ω ±200ppm/°C Epoxy Coating)

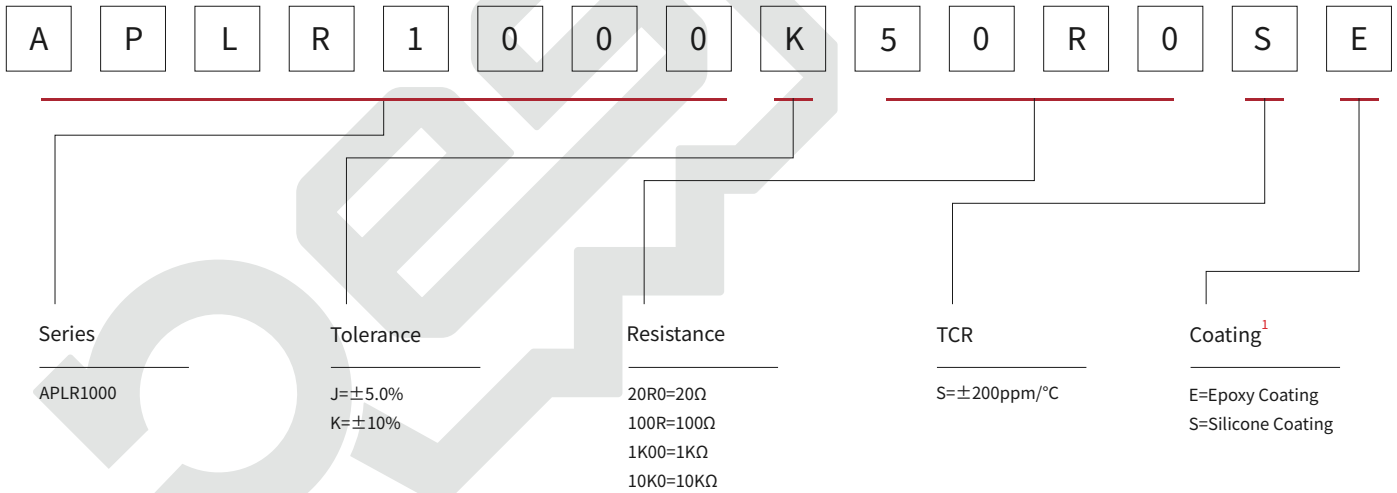

1. Epoxy resin packaging has higher insulation strength and moisture resistance; Silicone resin packaging has strong heat dissipation ability and can operate at higher temperatures.
Note: For higher/lower resistance, tighter tolerance, higher voltage, lower TCR and higher peak energy, please contact us.

Performance

Test	Test Method	Standards	Test Results
Voltage Proof (S Coating)	Apply 2500VAC between the lead and the silicone coating for 60s	IEC 60115-1 4.7	No breakdown or flashover, $\Delta R \leq \pm 0.5\%$
Voltage Proof (E Coating)	Apply 5000VAC between the lead and the epoxy coating for 60s	IEC 60115-1 4.7	No breakdown or flashover, $\Delta R \leq \pm 0.5\%$
Thermal Shock	-55°C, 15min~ambient temperature <20s~+125°C, 15min, 1000 cycles	MIL-STD-202 Method 107	$\Delta R \leq \pm 1.0\%$
Short Time Overload	Apply 10 times rated power for 5s, 90s off, 10 cycles	IEC60115-1-2008 4.13	$\Delta R \leq \pm 0.5\%$
High Temperature Storage	1000h @+125°C, no load	MIL-STD-202 Method 108	$\Delta R \leq \pm 1.0\%$
Moisture Resistance	+85°C, 85%RH, 10% rated power, 1000h	MIL-STD-202 Method 106	Epoxy Coating: $\Delta R \leq \pm 0.5\%$ Silicone Coating: $\Delta R \leq \pm 2.0\%$
Mechanical Shock	Half Sine Wave, peak acceleration 100g's, pulse duration 6ms, 3 times in each of six directions, on three different axes	MIL-STD-202 Method 213	$\Delta R \leq \pm 0.5\%$
Vibration	10-2000Hz for 1min, test in directions of X Y Z for 12h totally	MIL-STD-202 Method 204	$\Delta R \leq \pm 0.5\%$
Load Life	Apply rated power for 1000h, 1.5h on, 0.5h off (ambient temperature 70°C)	MIL-STD-202 Method 108	$\Delta R \leq \pm 2.0\%$
Solderability	+245°C tin bath for 3s	AEC-Q200 TEST 18 IEC 60115-1 4.17	No visible damage. 95% minimum coverage

Failure mode

When a product fails for overpulse or overpower, its typical failure mode is resistance exceeding the tolerance or open circuit.

Derating Curve

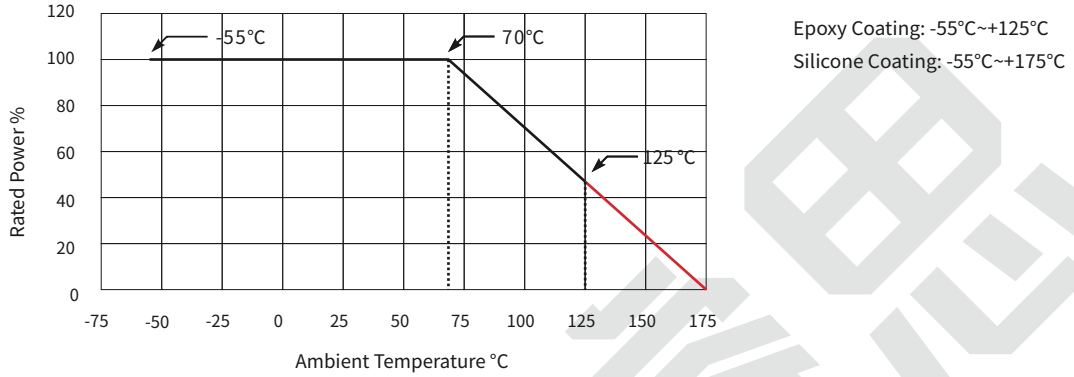

Construction

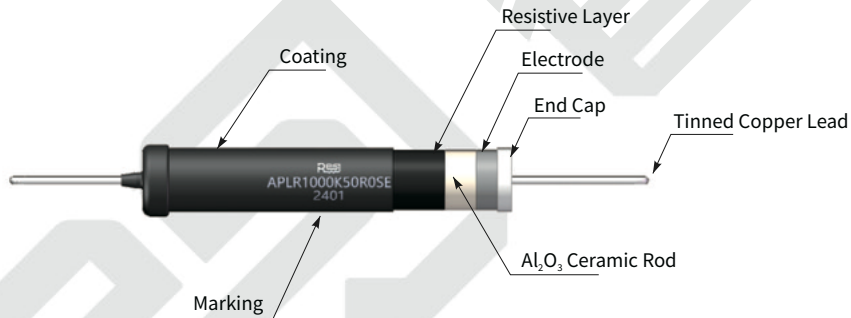

Marking

The first line (four digits) represents brand.
The second line (fifteen digits) represents part number.
The third line (four digits) represents date code.

Size

Illustration

Demonstration

APLR1000



RESI: Brand
APLR1000K50R0SE: Part Number
2401: Date Code

Installation

- (1) The following figure shows the APLR1000 common installation. The resistor should be installed horizontally between two land patterns and the lengths of the leads at both ends should be consistent.
- (2) As shown in the following figure, it is recommended to place the resistor marking facing upwards for reading the product part number and date code.
- (3) As shown in the following figure, it is recommended to maintain a gap of $\geq 1.5\text{mm}$ between the resistor and the PCB, because of the high voltage conditions of APLR1000.

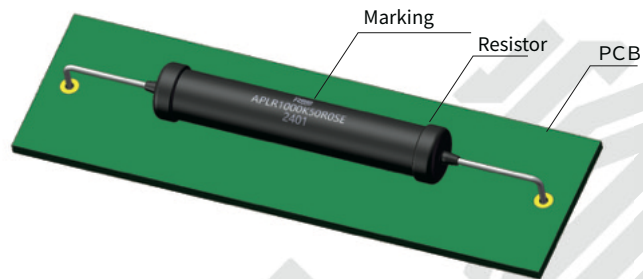

- (4) The minimum inner bending radius of the resistor lead is shown in the following table:

Lead Diameter (D)	Minimum Lead Inner Bending Radius (R)
< 0.6mm	1x Lead Diameter
0.6mm~1.2mm	1.5x Lead Diameter
>1.2mm	2x Lead Diameter

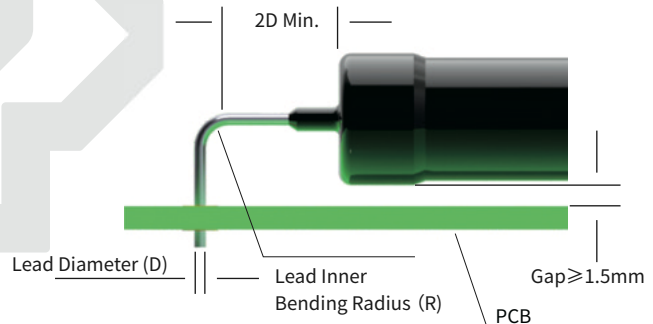

- (5) APLR1000 can be packaged and used in transformer oil.

Storage Instructions

- (1) Resistors should be stored at a temperature of 5 °C to 35 °C, humidity $\leq 60\%$ RH, and the humidity should be kept as low as possible.
- (2) Resistors should be protected from direct sunlight.
- (3) Resistors should be stored in a clean and dry environment, free of harmful gases (hydrogen chloride, sulfuric acid, hydrogen sulfide, etc).
- (4) Installation and storage should be handled carefully to prevent mechanical damage or deformation of the leads of the resistor caused by external impact.
- (5) Under the above conditions, resistors can be stored for at least 1 year.

Packaging

- (1) Place 25 pcs. resistors into an anti-static bag and vacuum seal it. The size of the anti-static bag is 150mm*130mm;
- (2) Place 4 vacuumed anti-static bags into a cardboard box and fill the gaps inside the cardboard box with bubble wrap to ensure that the product is not movable (100 pcs. / box);
- (3) The number and size of bubble wrap will be adjusted according to the actual situation, and the size of the cardboard box is 250mm*200mm*70mm.

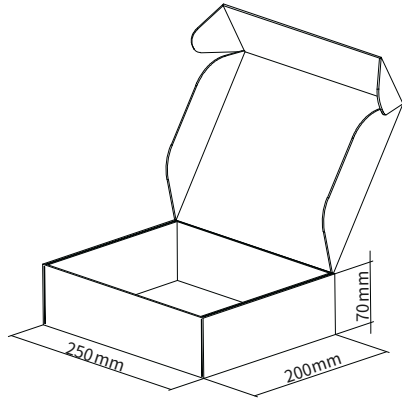

1. Prepare the cardboard box
250mm*200mm*70mm.

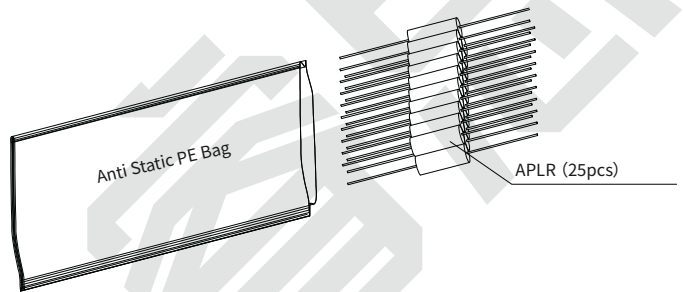

2. Place every 25 pcs. resistors into an anti-static vacuum bag for vacuum sealing, Vacuum bag size: 150mm*130mm (or similar specifications)

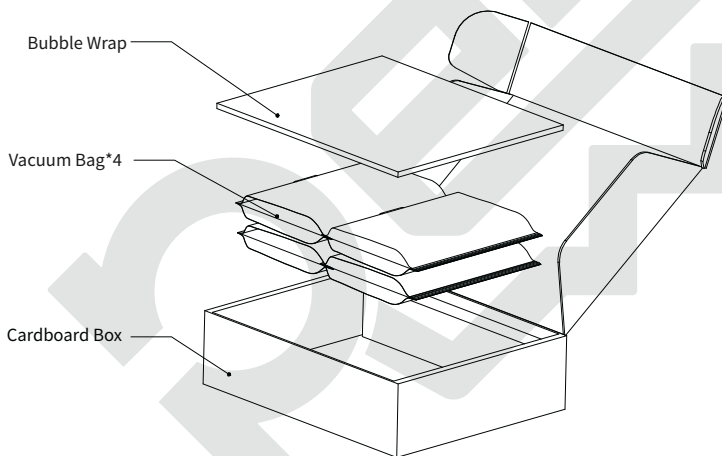

3. Place 4 vacuumed anti-static bags into a cardboard box and fill the gaps inside the cardboard box with bubble wrap to ensure that the product is not movable

4. Seal the box and label it.

Popular Part Numbers

Part Number	Peak Energy	Tolerance	Resistance	TCR	Power	Peak Voltage
APLR1000J20R0SE	1000J	±5.0%	20Ω	±200ppm/°C	6W	400V
APLR1000K20R0SE	1000J	±10%	20Ω	±200ppm/°C	6W	400V
APLR1000J50R0SE	1000J	±5.0%	50Ω	±200ppm/°C	6W	700V
APLR1000K50R0SE	1000J	±10%	50Ω	±200ppm/°C	6W	700V
APLR1000J100RSE	1000J	±5.0%	100Ω	±200ppm/°C	6W	1000V
APLR1000K100RSE	1000J	±10%	100Ω	±200ppm/°C	6W	1000V
APLR1000J150RSE	1000J	±5.0%	150Ω	±200ppm/°C	6W	1500V
APLR1000K150RSE	1000J	±10%	150Ω	±200ppm/°C	6W	1500V
APLR1000J200RSE	1000J	±5.0%	200Ω	±200ppm/°C	6W	1900V
APLR1000K200RSE	1000J	±10%	200Ω	±200ppm/°C	6W	1900V
APLR1000J300RSE	1000J	±5.0%	300Ω	±200ppm/°C	6W	2500V
APLR1000K300RSE	1000J	±10%	300Ω	±200ppm/°C	6W	2500V
APLR1000J500RSE	1000J	±5.0%	500Ω	±200ppm/°C	6W	3500V
APLR1000K500RSE	1000J	±10%	500Ω	±200ppm/°C	6W	3500V
APLR1000J1K00SE	1000J	±5.0%	1KΩ	±200ppm/°C	6W	5000V
APLR1000K1K00SE	1000J	±10%	1KΩ	±200ppm/°C	6W	5000V
APLR1000J2K00SE	1000J	±5.0%	2KΩ	±200ppm/°C	6W	5000V
APLR1000K2K00SE	1000J	±10%	2KΩ	±200ppm/°C	6W	5000V
APLR1000J3K30SE	1000J	±5.0%	3.3KΩ	±200ppm/°C	6W	5000V
APLR1000K3K30SE	1000J	±10%	3.3KΩ	±200ppm/°C	6W	5000V
APLR1000J4K70SE	1000J	±5.0%	4.7KΩ	±200ppm/°C	6W	5000V
APLR1000K4K70SE	1000J	±10%	4.7KΩ	±200ppm/°C	6W	5000V
APLR1000J10K0SE	1000J	±5.0%	10KΩ	±200ppm/°C	6W	5000V
APLR1000K10K0SE	1000J	±10%	10KΩ	±200ppm/°C	6W	5000V

Revision

Version	Revised Content	Date	Approver
V0	Initial Issue	2021.05.19	LWW
V1	Change datasheet to the new template.	2024.04.24	LWW
V2	Supplement information of product electrical parameters and failure modes	2024.05.13	LWW

Disclaimer

All products, datasheets and data can be changed without prior notice.

C&B Electronics Shenzhen CO., LTD., its affiliates, distributors, employees, and any other person acting on its behalf (collectively referred to as "C&B Electronics") shall not bear any legal responsibility for any errors, inaccuracies, or incompleteness of information related to the product disclosed under this agreement or other disclosures.

Product datasheet does not constitute an extension or revision of the purchase terms and conditions in C&B Electronics, including but not limited to the warranties under this agreement.

Unless specified in the purchase terms and conditions, C&B Electronics makes no guarantees, representations or warranties.

To the maximum extent permitted by applicable laws, C&B Electronics hereby makes the following disclaimer:

- (1) All liabilities arising from the use of the product;**
- (2) Including but not limited to all liabilities arising from special, indirect or incidental damages;**
- (3) All implied warranties, including warranties of suitability for special purposes, non infringement possibility, and marketability.**

The information provided in the datasheet and parameter tables may vary in different applications, and the performance of the product may change over time. The recommended application instructions for the product are based on C&B Electronics' understanding and experience of typical requirements. Customers are obligated to verify whether the product is suitable for a specific application based on the parameters provided in the datasheet. Before officially installing or using the product, you should ensure that you have obtained the latest version of relevant information, which can be obtained through the website: resistor.today.

The signing of this agreement does not constitute an express, implied or other form of license related to all intellectual property rights of C&B Electronic Products.

Unless explicitly stated, the products listed in this agreement are not applicable to lifesaving or life sustaining products. In the absence of a clear indication, the customer shall bear all risks caused by unauthorized use of the above products and agree to fully compensate C&B Electronics for all losses caused by such sales or use. For written product terms for such special applications, please contact authorized personnel from C&B Electronics to obtain.

The names and markings on the listed products may be trademarks owned by others.