

## Planar Non-inductive Power Resistor

# SOTC0227

Resistance **0.1Ω~1MΩ**

Tolerance **±0.5%**

TCR **±100ppm/°C**

Rated Power **300W**

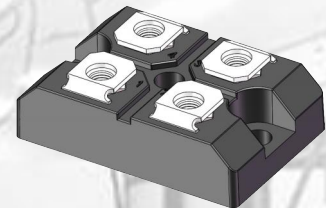

Applicable to

Precision Test and Measurement  
Semiconductor Equipment  
Automotive Electronics  
Industrial Electrical Equipment

## High Power with Excellent Reliability & Stability

### Introduction

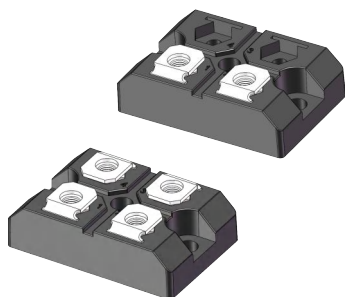

SOTC0227 is a SOT-227 non-inductive high-power resistor. The SOT-227 transistor outline package is a SOT227 package, commonly used for high-power transistors, small to medium-sized integrated circuits, power resistors, etc.

The rated power of SOTC0227 series is 300W. SOTC0227 adopts a flange for its better heat dissipation to balance the thermal characteristics of the circuit. It is usually designed for current measurement, energy absorption, discharge, RC absorption, high-speed switching, high frequency transmission circuits, voltage regulation, constant power loads, and low-energy pulse loads. Its industry applications include industrial lasers, welding equipment, testing equipment, instrumentation, UPS, automobiles, switching power supplies, etc.

SOTC0227 series high-power molded resistor has excellent long-term stability, low TCR, high heat dissipation, low thermal resistance and low current noise, applying for a wide range. From raw materials, core production equipment, to process technology, SOTC0227 production is independent and controllable and achieves stable quality and timely delivery.



### Electrical Parameters

Series	Resistance Ω	TCR ppm/°C(+20°CRef)	Tolerance %	Max. Operating Voltage <sup>1</sup>	Rated Power <sup>2</sup> With Heat Sink. Flange≤25°C	Operating Temperature
SOTC0227	0.1≤R≤1M	±100	±0.5, ±1, ±5	1000V	300W	-55~+155°C
Galvanic Isolation	Insulation Resistance	Thermal Resistance	Inductance <sup>3</sup>	E-Series Value	Technology	Unit Weight
4000VAC	≥1G	0.32°C/W	≤0.1μH	E24	Thick Film	23.5±2.0g

1. According to  $P=UI$ , combined with power and the maximum operating voltage, calculate the maximum current value ( $P$  and  $U$  whichever is less).
2. If the actual operating power is greater than 5.0W, it must be used with a heat sink. The recommended heat sink and installation method refer to pages 5 and 6.
3. When resistance is between 0.1Ω ~ 1KΩ, the applicable testing frequency range is 1kHz ~ 1MHz. When the resistance value is between 1KΩ ~ 1MΩ, the applicable testing frequency range is 1kHz ~ 100kHz. If higher application frequency is required, it needs to be verified through actual operating conditions testing or contact us.

### Dimensions

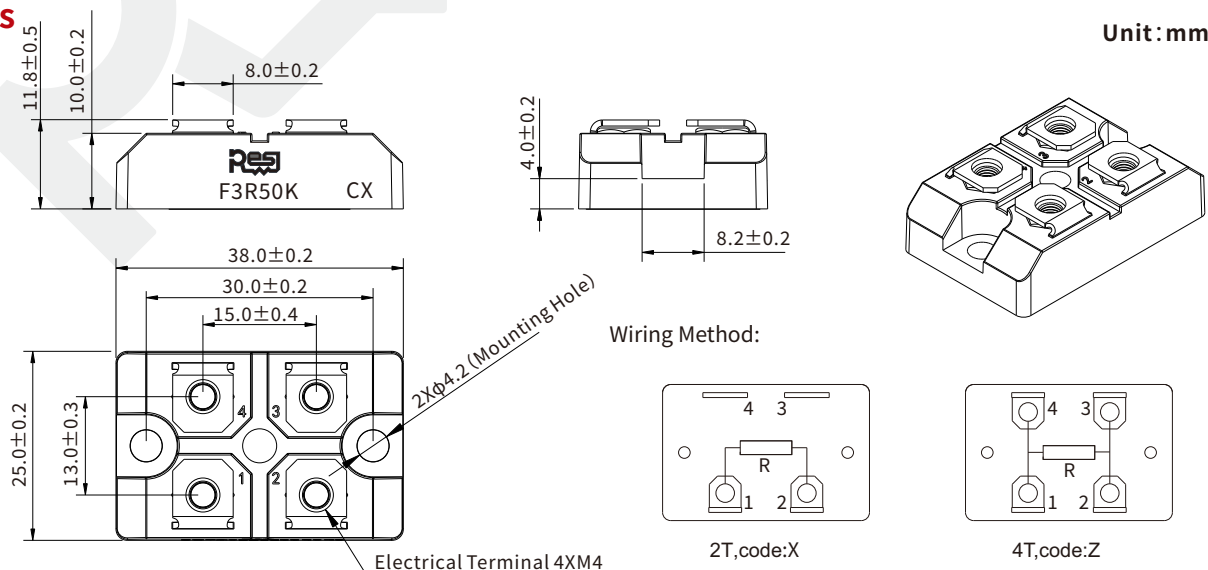

## Construction

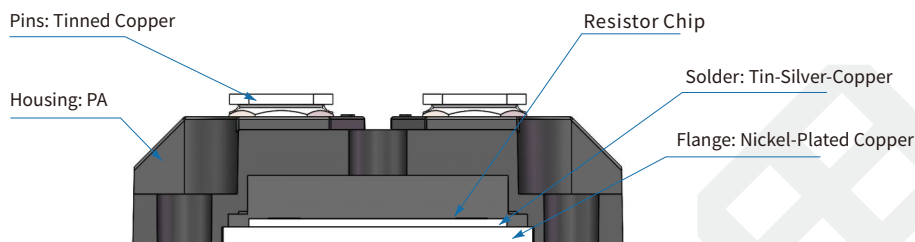

## Marking

Composition of Product Silk Screen Printing: Brand+tolerance+resistance+TCR+series code+wiring method

Series	Illustration	E-Series Value	Demonstration
SOTC0227		E24	RESI: Brand F: tolerance 3R50: resistance K: TCR C : SOT0227 300W X: 2T

## Part Number Information

Example: SOTC0227F3R50KZ ( SOTC0227series  $\pm 1\%$  3.5 $\Omega$   $\pm 100$ ppm/ $^{\circ}$ C 4T )

S	O	T	C	0	2	2	7	F	3	R	5	0	K	Z
Series				Package				Tolerance	Resistance				TCR	Code
SOTC				0227				D=±0.5% F=±1% J=±5%	R500=0.5 $\Omega$ 3R00=3 $\Omega$ 1K00=1K $\Omega$ 10K0=10K $\Omega$				K=±100ppm/ $^{\circ}$ C	Z=4T X=2T Others=Custom

Noted: For higher/lower resistance, tighter tolerance, higher power, lower TCR and larger size, please contact us.

### Derating Curve

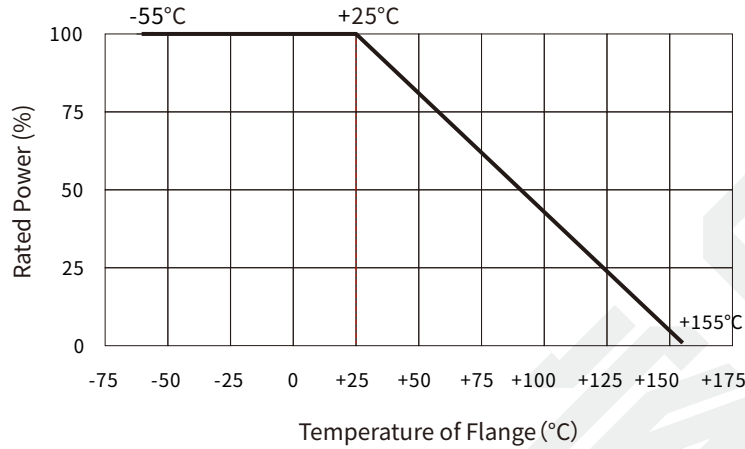

### Power - Temperature Rise Curve

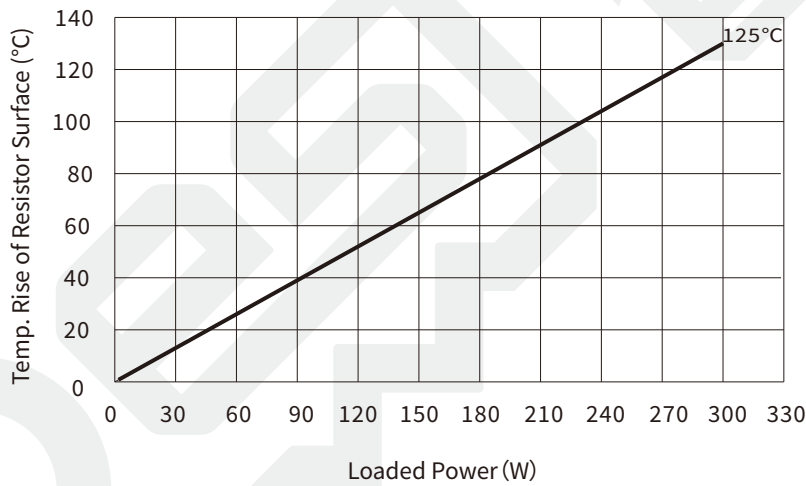

### Pulse Power Curve

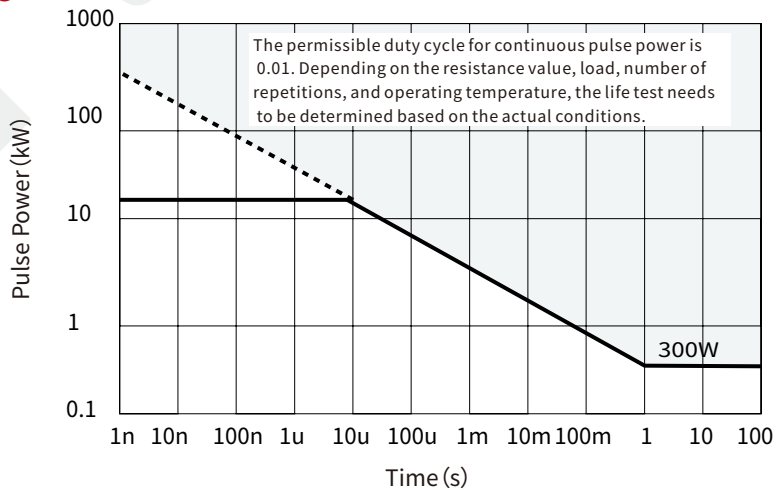

### Performance

Test	Test Method	Standards	Performance
High Temperature Storage	1000h@+155°C,unpowered.	AEC-Q200 TEST 3 MIL-STD-202 Method 108	$\Delta R \leq \pm 1\%$
Bias Humidity	+85°C,85%RH,powered 10% rated power for 1000h. Inspect within 24±4 hours after the test.	AEC-Q200 TEST 7 MIL-STD-202 Method 103	$\Delta R \pm \leq 0.5\%$
Load Life	Water-cooled heat sink inlet water temperature: 25°C, 1000h, rated power,not exceeding maximum operating voltage,90 min on,30 min off.	AEC-Q200 TEST 8 MIL-STD-202 Method 108	$\Delta R \leq \pm 1\%$
Resistance to Solvent	Three types of solvents were used. Immerse (the item) in the solvent for 5 minutes,wipe ten times,then clean and dry at room temperature.	AEC-Q200 TEST 12 MIL-STD-202 Method 215	Clear marking. No visible damage
Mechanical Shock	Half Sine Wave, peak acceleration 100g's,pulse duration 6ms, 3 times in each of six directions, on three different axes.	AEC-Q200 TEST 13 MIL-STD-202 Method 213	$\Delta R \leq \pm 0.5\%$
Vibration	10-2KHz,5g's,20min/cycle,12 cycles in each directions of X Y Z.	AEC-Q200 TEST 14 MIL-STD-202 Method 204	$\Delta R \leq \pm 0.5\%$
Thermal Shock	-55°C,15min~ambient temperature<20s~+125°C,15min,1000 cycles.	AEC-Q200 TEST 16 MIL-STD-202 Method 107	$\Delta R \leq \pm 0.5\%$
TCR	-55°C ~ +125°C,+20°C Ref.	MIL-STD-202 Method 304 IEC 60115-1 4.8	Within the nominal value range
Flammability	Flame the sample for 10 seconds,twice.	UL-94	UL-94 V0
Terminal Strength	Mounting 1.6Nm,Electrical Terminal 1.2Nm.	IEC60115-1 4.16	No breakdown or flashover, $\Delta R \leq \pm 0.1\%$ .
Withstand Voltage	Apply an effective 4000VAC between the terminal and flange for 60 seconds.	MIL-STD-202Method 301	No breakdown or flashover $\Delta R \leq \pm 0.5\%$
Short Time Overload	2x rated power (5W) for 5s,not exceeding 1.5x maximum operating voltage.	IEC 60115-1 4.13	$\Delta R \leq \pm 0.5\%$
Low Temperature Operation	-55 °C,unpowered for 1h,powered rated voltage for 45 min, unpowered for 15 min.	IEC 60115-1 4.36	$\Delta R \leq \pm 0.5\%$

### Packaging

- 1、Tube: Transparent PVC packaging tube, each tube contains 7 pcs, the external dimensions of the packaging tube are approximately 323mm\*28mm\*16mm (Pic. 1)。
- 2、Transport Package : Seven-layer corrugated box, each box contains 40 tubes, the external dimensions of the box are approximately 370mm\*290mm\*85mm (Pic. 2)。

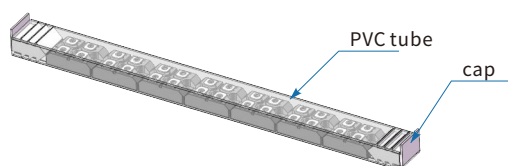

Pic. 1



Pic. 2

### Installation

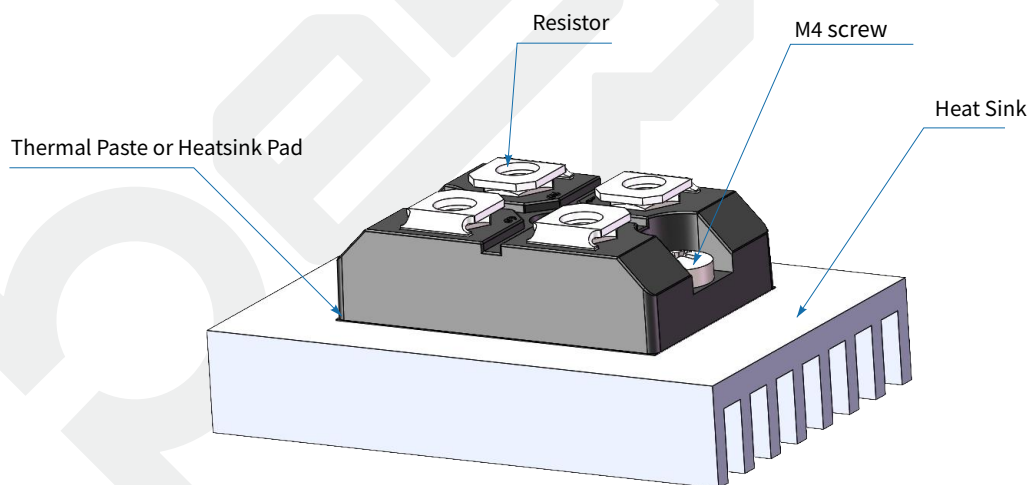

- (1) The general installation of SOT-227 resistors is shown in the figure above. For good thermal conductivity, thermal paste or heatsink pads must be used at the contact position between the bottom of the resistor flange and the heat sink, to ensure contact area for heat dissipation;
- (2) The bolt connecting the flange with the heat sink should be of a specification with spring washers to prevent looseness and sliding during long-term use, which may cause gaps and affect the thermal conductivity.;
- (3) The Electrical Terminal screw torque is 1.0Nm(Max.), the Mounting screw torque is 1.3Nm(Max.), to avoid cracks or warping deformation of the product caused by excessive torque;
- (4) For full power application, it is necessary to refer to the derating curve diagram and ensure that the temperature of the bottom flange is  $\leq 25^{\circ}\text{C}$  by using water cooling or oil cooling to ensure the load life and reliability of the resistor.

### Statement of Rated Power and Temperature

The maximum rated power of SOTC0227 series high-power resistor is 300W, which is based on 25 °C operating ambient temperature of the flange. The temperature measurement point is in the center of the back of the flange, which is below the resistive element. The temperature of the resistor flange is different from the temperature of the housing, pin or ambient temperature. The heat dissipation effect of the resistor can be reflected by the flange temperature. Heat dissipation effect is a crucial factor. When equipment or resistor fails, please investigate the heat dissipation of the resistor first. If the flange is overtemperature, it usually indicates that the heat dissipation effect has not achieved the conditions specified in the datasheet, which means the installation of the heat sink or the heat dissipation capacity of the applied heat sink does not meet the requirements. Long-term use can lead to drift of the resistance, thereby reducing the load life of the resistor. When using resistors, it is recommended to apply appropriate thermal design, calculation, and temperature measurement or finite element analysis to verify the feasibility of the design and avoid resistor failure due to poor heat dissipation.

### Temperature Diagram of Product Assembly

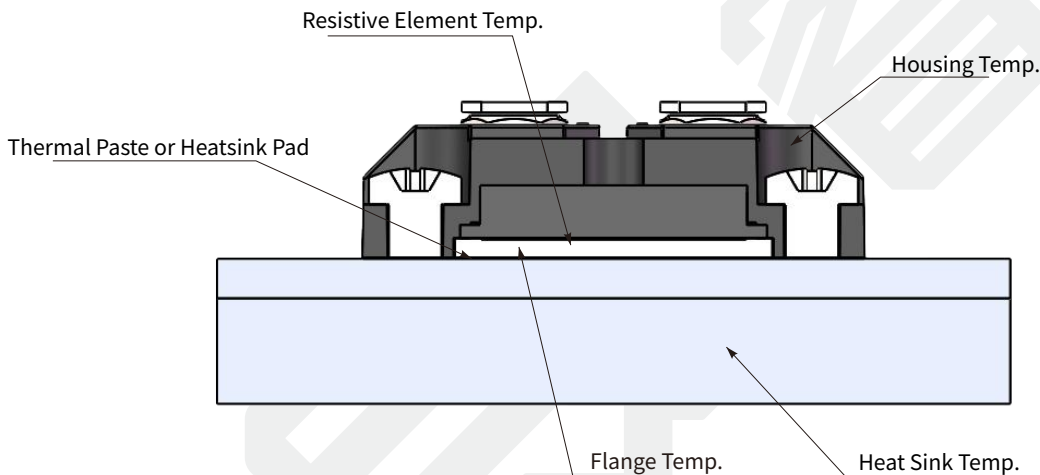

### Heat Sink Selection

Users must choose a suitable heat sink based on the usage conditions of the resistors (e.g. power, ambient temperature, etc.). The maximum operating temperature of SOTC0227 series is 155°C. SOTC0227 power calculation is as follows:

$$P = \frac{\Delta T}{R_{TH(j-c)} + R_{TH(c-h)} + R_{TH(h-a)}}$$

P: The operating power of the resistor;

ΔT: The difference of the maximum operating temperature of the resistor and the ambient temperature;

$R_{TH(j-c)}$ : The thermal resistance between the resistive layer and the outer part of the resistor, i.e. the thermal resistance of the resistor;

$R_{TH(c-h)}$ : The thermal resistance between the outer part of the resistor and the upper part of the heat sink, i.e. the thermal resistance at TH (c-h) the contact interface;

$R_{TH(h-a)}$ : The thermal resistance of the heat sink.

Example::

$R_{TH(h-a)}$  :: Determine an operating power of 200W and an ambient temperature of +25 °C for SOTC0227 ;

Referring to the datasheet, the thermal resistance  $R_{TH(j-c)}$  of SOTC0227 series is 0.32°C/W;

The calculation is as follows::

$$\Delta T = 155^{\circ}\text{C} - 25^{\circ}\text{C} = 130^{\circ}\text{C}$$

$$R_{TH(j-c)} + R_{TH(c-h)} + R_{TH(h-a)} = \Delta T / P = 0.65^{\circ}\text{C}/\text{W}$$

$$R_{TH(c-h)} + R_{TH(h-a)} = 0.65 - 0.32 = 0.33^{\circ}\text{C}/\text{W}$$

The thermal resistance at the contact interface,  $R_{TH(c-h)}$  can be concluded, based on the operating condition. If  $R_{TH(c-h)}$  is 0.1 °C/W, a heat sink with  $R_{TH(h-a)}$  less than 0.23°C/W is needed.

## Popular Part Numbers

Part Number	Package	Tolerance	Resistance	TCR	Rated Power	Max. Operating Voltage	Wiring Method
SOTC0227FR100KZ	SOTC0227	±1%	0.1Ω	±100ppm/°C	300W	1000V	4T
SOTC0227FR500KZ	SOTC0227	±1%	0.5Ω	±100ppm/°C	300W	1000V	4T
SOTC0227F1R00KZ	SOTC0227	±1%	1Ω	±100ppm/°C	300W	1000V	4T
SOTC0227F2R00KZ	SOTC0227	±1%	2Ω	±100ppm/°C	300W	1000V	4T
SOTC0227F3R50KZ	SOTC0227	±1%	3.5Ω	±100ppm/°C	300W	1000V	4T
SOTC0227F4R70KZ	SOTC0227	±1%	4.7Ω	±100ppm/°C	300W	1000V	4T
SOTC0227F5R00KZ	SOTC0227	±1%	5Ω	±100ppm/°C	300W	1000V	4T
SOTC0227F7R50KZ	SOTC0227	±1%	7.5Ω	±100ppm/°C	300W	1000V	4T
SOTC0227F10R0KZ	SOTC0227	±1%	10Ω	±100ppm/°C	300W	1000V	4T
SOTC0227F20R0KZ	SOTC0227	±1%	20Ω	±100ppm/°C	300W	1000V	4T
SOTC0227F33R0KZ	SOTC0227	±1%	33Ω	±100ppm/°C	300W	1000V	4T
SOTC0227F50R0KZ	SOTC0227	±1%	50Ω	±100ppm/°C	300W	1000V	4T
SOTC0227F100RKZ	SOTC0227	±1%	100Ω	±100ppm/°C	300W	1000V	4T
SOTC0227F200RKZ	SOTC0227	±1%	200Ω	±100ppm/°C	300W	1000V	4T
SOTC0227F500RKZ	SOTC0227	±1%	500Ω	±100ppm/°C	300W	1000V	4T
SOTC0227F1K00KZ	SOTC0227	±1%	1kΩ	±100ppm/°C	300W	1000V	4T
SOTC0227F5K00KZ	SOTC0227	±1%	5kΩ	±100ppm/°C	300W	1000V	4T
SOTC0227F10K0KZ	SOTC0227	±1%	10kΩ	±100ppm/°C	300W	1000V	4T
SOTC0227F100KKZ	SOTC0227	±1%	100kΩ	±100ppm/°C	300W	1000V	4T
SOTC0227F500KKZ	SOTC0227	±1%	500kΩ	±100ppm/°C	300W	1000V	4T
SOTC0227F1M00KZ	SOTC0227	±1%	1MΩ	±100ppm/°C	300W	1000V	4T
SOTC0227JR100KZ	SOTC0227	±5%	0.1Ω	±100ppm/°C	300W	1000V	4T
SOTC0227JR500KZ	SOTC0227	±5%	0.5Ω	±100ppm/°C	300W	1000V	4T
SOTC0227J1R00KZ	SOTC0227	±5%	1Ω	±100ppm/°C	300W	1000V	4T
SOTC0227J2R00KZ	SOTC0227	±5%	2Ω	±100ppm/°C	300W	1000V	4T
SOTC0227J3R50KZ	SOTC0227	±5%	3.5Ω	±100ppm/°C	300W	1000V	4T
SOTC0227J4R70KZ	SOTC0227	±5%	4.7Ω	±100ppm/°C	300W	1000V	4T
SOTC0227J5R00KZ	SOTC0227	±5%	5Ω	±100ppm/°C	300W	1000V	4T
SOTC0227J7R50KZ	SOTC0227	±5%	7.5Ω	±100ppm/°C	300W	1000V	4T
SOTC0227J10R0KZ	SOTC0227	±5%	10Ω	±100ppm/°C	300W	1000V	4T
SOTC0227J20R0KZ	SOTC0227	±5%	20Ω	±100ppm/°C	300W	1000V	4T
SOTC0227J33R0KZ	SOTC0227	±5%	33Ω	±100ppm/°C	300W	1000V	4T
SOTC0227J50R0KZ	SOTC0227	±5%	50Ω	±100ppm/°C	300W	1000V	4T
SOTC0227J100RKZ	SOTC0227	±5%	100Ω	±100ppm/°C	300W	1000V	4T
SOTC0227J200RKZ	SOTC0227	±5%	200Ω	±100ppm/°C	300W	1000V	4T
SOTC0227J500RKZ	SOTC0227	±5%	500Ω	±100ppm/°C	300W	1000V	4T
SOTC0227J1K00KZ	SOTC0227	±5%	1KΩ	±100ppm/°C	300W	1000V	4T
SOTC0227J5K00KZ	SOTC0227	±5%	5KΩ	±100ppm/°C	300W	1000V	4T
SOTC0227J10K0KZ	SOTC0227	±5%	10KΩ	±100ppm/°C	300W	1000V	4T
SOTC0227J100KKZ	SOTC0227	±5%	100KΩ	±100ppm/°C	300W	1000V	4T
SOTC0227D500KKZ	SOTC0227	±5%	500KΩ	±100ppm/°C	300W	1000V	4T
SOTC0227D1M00KZ	SOTC0227	±5%	1MΩ	±100ppm/°C	300W	1000V	4T
SOTC0227FR100KX	SOTC0227	±1%	0.1Ω	±100ppm/°C	300W	1000V	2T
SOTC0227FR500KX	SOTC0227	±1%	0.5Ω	±100ppm/°C	300W	1000V	2T
SOTC0227F1R00KX	SOTC0227	±1%	1Ω	±100ppm/°C	300W	1000V	2T
SOTC0227F2R00KX	SOTC0227	±1%	2Ω	±100ppm/°C	300W	1000V	2T
SOTC0227F3R50KX	SOTC0227	±1%	3.5Ω	±100ppm/°C	300W	1000V	2T
SOTC0227F4R70KX	SOTC0227	±1%	4.7Ω	±100ppm/°C	300W	1000V	2T
SOTC0227F5R00KX	SOTC0227	±1%	5Ω	±100ppm/°C	300W	1000V	2T
SOTC0227F7R50KX	SOTC0227	±1%	7.5Ω	±100ppm/°C	300W	1000V	2T
SOTC0227F10R0KX	SOTC0227	±1%	10Ω	±100ppm/°C	300W	1000V	2T
SOTC0227F20R0KX	SOTC0227	±1%	20Ω	±100ppm/°C	300W	1000V	2T

## Popular Part Numbers

Part Number	Package	Tolerance	Resistance	TCR	Rated Power	Max. Operating Voltage	Wiring Method
SOTC0227F33R0KX	SOTC0227	±1%	33Ω	±100ppm/°C	300W	1000V	2T
SOTC0227F50R0KX	SOTC0227	±1%	50Ω	±100ppm/°C	300W	1000V	2T
SOTC0227F100R0KX	SOTC0227	±1%	100Ω	±100ppm/°C	300W	1000V	2T
SOTC0227F200R0KX	SOTC0227	±1%	200Ω	±100ppm/°C	300W	1000V	2T
SOTC0227F500R0KX	SOTC0227	±1%	500Ω	±100ppm/°C	300W	1000V	2T
SOTC0227F1K00KX	SOTC0227	±1%	1kΩ	±100ppm/°C	300W	1000V	2T
SOTC0227F5K00KX	SOTC0227	±1%	5kΩ	±100ppm/°C	300W	1000V	2T
SOTC0227F10K0KX	SOTC0227	±1%	10kΩ	±100ppm/°C	300W	1000V	2T
SOTC0227F100K0KX	SOTC0227	±1%	100kΩ	±100ppm/°C	300W	1000V	2T
SOTC0227F500K0KX	SOTC0227	±1%	500kΩ	±100ppm/°C	300W	1000V	2T
SOTC0227F1M00KX	SOTC0227	±1%	1MΩ	±100ppm/°C	300W	1000V	2T
SOTC0227JR100KX	SOTC0227	±5%	0.1Ω	±100ppm/°C	300W	1000V	2T
SOTC0227JR500KX	SOTC0227	±5%	0.5Ω	±100ppm/°C	300W	1000V	2T
SOTC0227J1R00KX	SOTC0227	±5%	1Ω	±100ppm/°C	300W	1000V	2T
SOTC0227J2R00KX	SOTC0227	±5%	2Ω	±100ppm/°C	300W	1000V	2T
SOTC0227J3R50KX	SOTC0227	±5%	3.5Ω	±100ppm/°C	300W	1000V	2T
SOTC0227J4R70KX	SOTC0227	±5%	4.7Ω	±100ppm/°C	300W	1000V	2T
SOTC0227J5R00KX	SOTC0227	±5%	5Ω	±100ppm/°C	300W	1000V	2T
SOTC0227J7R50KX	SOTC0227	±5%	7.5Ω	±100ppm/°C	300W	1000V	2T
SOTC0227J10R0KX	SOTC0227	±5%	10Ω	±100ppm/°C	300W	1000V	2T
SOTC0227J20R0KX	SOTC0227	±5%	20Ω	±100ppm/°C	300W	1000V	2T
SOTC0227J33R0KX	SOTC0227	±5%	33Ω	±100ppm/°C	300W	1000V	2T
SOTC0227J50R0KX	SOTC0227	±5%	50Ω	±100ppm/°C	300W	1000V	2T
SOTC0227J100R0KX	SOTC0227	±5%	100Ω	±100ppm/°C	300W	1000V	2T
SOTC0227J200R0KX	SOTC0227	±5%	200Ω	±100ppm/°C	300W	1000V	2T
SOTC0227J500R0KX	SOTC0227	±5%	500Ω	±100ppm/°C	300W	1000V	2T
SOTC0227J1K00KX	SOTC0227	±5%	1KΩ	±100ppm/°C	300W	1000V	2T
SOTC0227J5K00KX	SOTC0227	±5%	5KΩ	±100ppm/°C	300W	1000V	2T
SOTC0227J10K0KX	SOTC0227	±5%	10KΩ	±100ppm/°C	300W	1000V	2T
SOTC0227J100K0KX	SOTC0227	±5%	100KΩ	±100ppm/°C	300W	1000V	2T
SOTC0227D500K0KX	SOTC0227	±5%	500KΩ	±100ppm/°C	300W	1000V	2T
SOTC0227D1M00KX	SOTC0227	±5%	1MΩ	±100ppm/°C	300W	1000V	2T

## Revision

Version	Revised Content	Date	Approver
V0	Initial Issue	2025.10.15	LWW
V1	Adjust the layout	2026.04.02	LWW

---

## Disclaimer

---

All products, datasheets and data can be changed without prior notice.

C&B Electronics Shenzhen CO., LTD., its affiliates, distributors, employees, and any other person acting on its behalf (collectively referred to as "C&B Electronics") shall not bear any legal responsibility for any errors, inaccuracies, or incompleteness of information related to the product disclosed under this agreement or other disclosures.

Product datasheet does not constitute an extension or revision of the purchase terms and conditions in C&B Electronics, including but not limited to the warranties under this agreement.

Unless specified in the purchase terms and conditions, C&B Electronics makes no guarantees, representations or warranties.

**To the maximum extent permitted by applicable laws, C&B Electronics hereby makes the following disclaimer:**

- (1) All liabilities arising from the use of the product;**
- (2) Including but not limited to all liabilities arising from special, indirect or incidental damages;**
- (3) All implied warranties, including warranties of suitability for special purposes, non infringement possibility, and marketability.**

The information provided in the datasheet and parameter tables may vary in different applications, and the performance of the product may change over time. The recommended application instructions for the product are based on C&B Electronics' understanding and experience of typical requirements. Customers are obligated to verify whether the product is suitable for a specific application based on the parameters provided in the datasheet. Before officially installing or using the product, you should ensure that you have obtained the latest version of relevant information, which can be obtained through the website: [resistor.today](http://resistor.today).

The signing of this agreement does not constitute an express, implied or other form of license related to all intellectual property rights of C&B Electronic Products.

Unless explicitly stated, the products listed in this agreement are not applicable to lifesaving or life sustaining products. In the absence of a clear indication, the customer shall bear all risks caused by unauthorized use of the above products and agree to fully compensate C&B Electronics for all losses caused by such sales or use. For written product terms for such special applications, please contact authorized personnel from C&B Electronics to obtain.

The names and markings on the listed products may be trademarks owned by others.