

1 Description

The RedRock™ RR111 Series is a magnetic sensor with a continuous analog output linearly proportional to an applied magnetic field. Ideal for use in medical, industrial, automotive, and consumer applications, they are based on patented Tunneling Magnetoresistance (TMR) technology with seamless CMOS integration. The RR111 enables applications like proximity sensing, and continuous level detection.

The RR111 features a low average current drain (1.6 mA) for a continuously active magnetic sensor and temperature range from -40°C up to 85°C. It comes in an SOT-23-3 package measuring 2.9 x 1.6 x 1.2 mm as well as an LGA-4 package measuring just 1.4 x 1.4 x 0.45 mm.

Device Information

Part Series	Package	Body Size (mm)
RR111	SOT-23-3	2.9 x 1.6 x 1.2
	LGA-4	1.4 x 1.4 x 0.45

Device Packages



2 Features

- ▶ Zero Hysteresis
- ▶ Low Current of 1.5 mA
- ▶ Omnipolar Sensitivity
- ▶ Continuous Operation
- ▶ Temperature Rated up to 85°C
- ▶ RoHS & REACH Compliant

3 Applications

- ▶ Proximity Detection
- ▶ Rotary Sensing
- ▶ Fluid Level Detection
- ▶ Door & Lid Closure Detection
- ▶ Utility Meters
- ▶ Portable Medical Devices
- ▶ Motor Controllers
- ▶ Consumer Electronics
- ▶ Wake-Up μ Processor

Functional Block Diagram

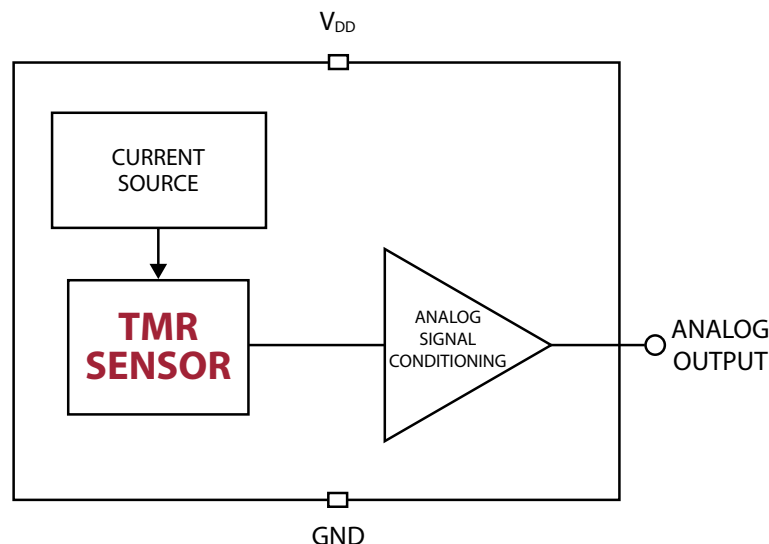

Table of Contents

1. Description	1
2. Features	1
3. Applications	1
4. Specifications	3
4.1 Absolute Environmental Ratings	3
4.2 Absolute Electrical Ratings	3
4.3 Operating Electrical Characteristics	3
4.4 Operating Characteristics	4
5. Application Information	4
5.1 RR111 Output Application Circuit SOT-23-3	4
5.2 RR111 Output Application Circuit LGA-4	4
6. Part Selection & Ordering Information	5
6.1 Part Selection Table	5
6.2 Device Nomenclature Ordering Information	5
7. Axis of Sensitivity	5
8. Dimensions	6
8.1 SOT-23-3 Package Dimensions	6
8.2 LGA-4 Package Dimensions	6
9. TMR Sensor Location	7
9.1 SOT-23-3 Package	7
9.2 LGA-4 Package	7
10. Magnetic Flux Response Diagram	7
10.1 Omnipolar Magnetic Flux Response	7
11. Suggested Pb-Free Reflow Profile	8
12. TMR Sensor & Switch Packaging	9
12.1 SOT-23-3 Tape & Reel Packaging	9
12.2 LGA-4 Tape & Reel Packaging	10

4 Specifications

4.1 Absolute Environmental Ratings

Parameters	Units	Min	Typ	Max
Operating Temperature	°C	-40		85
Storage Temperature	°C	-55		150
Maximum Junction Temperature	°C			150
Soldering Temperature (3 cycles, 1 min.)	°C			260
ESD Level (HBM)	V			4000

4.2 Absolute Electrical Ratings¹

Parameters	Units	Min	Typ	Max
Supply Voltage (V_{DD})	V	-0.3		+4.0
Input and Output Current (I_{IN}/I_{OUT})	mA	-10		+10

4.3 Operating Electrical Characteristics¹

Parameters	Units	Min	Typ	Max
Supply Voltage (V_{DD})	V	+2.7	+3.0	+3.6
Power-On Time (t_{ON})($V_{DD} > 2.7V$)	μs		500	
Under-Voltage Lockout Threshold Rising V_{DD} (V_{UVLO_RISE})	V		+2.20	+2.60
Under-Voltage Lockout Threshold Falling V_{DD} (V_{UVLO_FALL})	V	+1.90	+2.15	
Under-Voltage Lockout Hysteresis (V_{UV_HYST})	mV		+50	

Notes:

1. Unless otherwise specified, all characteristics are measured at 25°C



ESD Note: This product uses semiconductors that can be damaged by electrostatic discharge (ESD). When handling, proper ESD precautions should be taken to avoid performance degradation or loss of functionality. Damage due to inappropriate handling is not covered under warranty.

4.4 Operating Characteristics¹

Parameters	Units	Min	Typ	Max
Operating Temperature (T _A)	°C	-40		+85
Average Supply Current (I _{DD(AVG)})(t = 10s)	mA		1.5	2.7
Maximum Drive Capability (I _{DRV(MAX)}) (V _{ANA} covers 20% V _{DD} to 80% V _{DD} span)	μA	-10		+10
Output Capacitive Load (C _L)	pF			10
Analog Output Magnetic Field Range (B _{ANA})	G	-10		+10
Analog Output Voltage Range (V _{ANA})	V	0.19 x V _{DD}		0.81 x V _{DD}
Voltage Output Quiescent (V _{OO}) ²	%V _{DD}	45	50	55
Sensitivity @ T = +25°C (T _A = +25°C)	mV/V/G	-17.6	-20	-22.4
Sensitivity @ Full Temperature Range (S _{FULL_RANGE}) (T _A = -40°C to +85°C)	mV/V/G	-14	-20	-26

Notes:

1. Unless otherwise specified, all characteristics are measured at 25°C
2. No magnetic field present.

5 Application Information

5.1 Application Circuit (SOT-23)

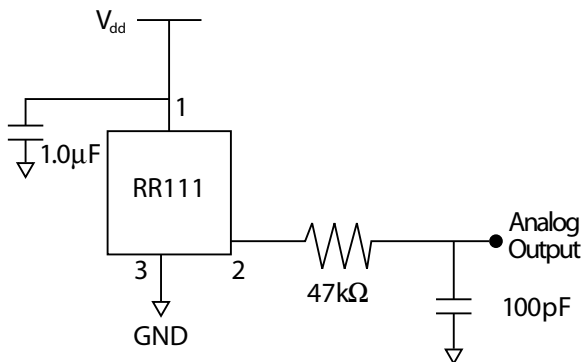

5.2 Application Circuit (LGA-4)

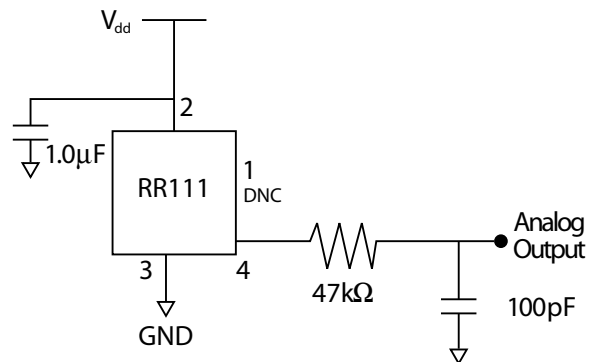

RR111 Output Application Circuit

The output voltage can be connected to an analog I/O pin on a microcontroller. A decoupling capacitor between the supply voltage and ground is required with placement close to the magnetic sensor. A typical capacitor value of 1.0 μF will suffice. The analog output voltage is proportional to the strength of an applied magnetic field. A simple RC filter is recommended at the output. A resistor value of 47kΩ and a capacitor value of 100 pF should suffice.

6 Part Selection and Ordering Information

6.1 Part Selection Table

Part Number	Magnetic Polarity Response	Frequency (Hz)	I_{avg} (uA)	Temp. Rating (°C)	Supply Voltage (V_{dd})	Output Response	Package
RR111-1DC2-331	Omnipolar	Continuous	1.5	-40 - +85	3	Analog	SOT-23-3
RR111-1DC2-332	Omnipolar	Continuous	1.5	-40 - +85	3	Analog	LGA-4

6.2 Device Nomenclature

Ordering Information

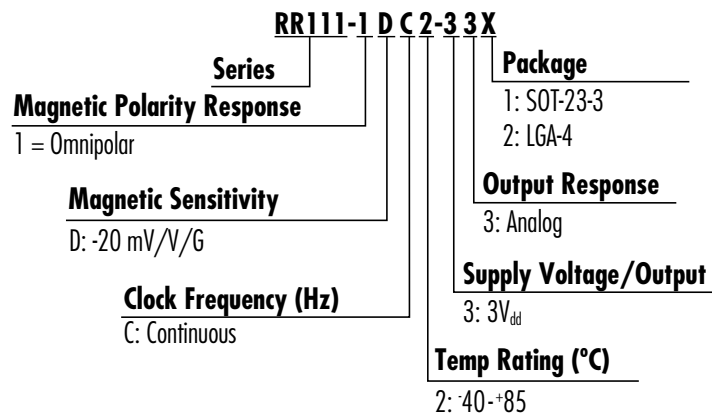

7 Axis of Sensitivity

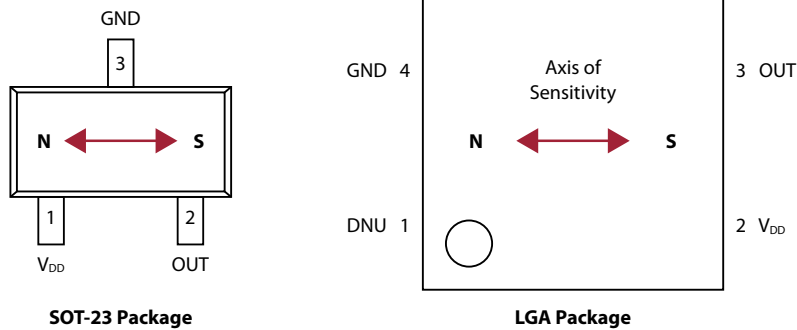

8 Dimensions *Millimeters (Inches)*

8.1 SOT-23-3 Package

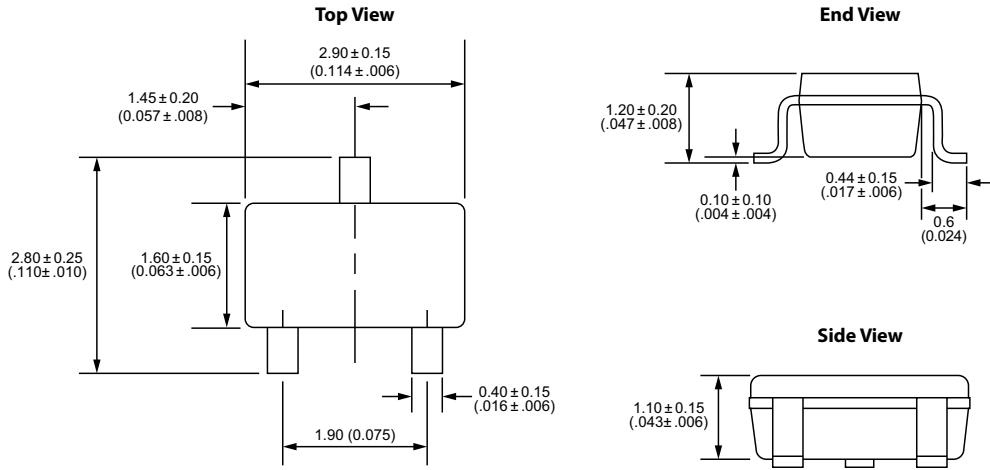

8.2 LGA-4 Package

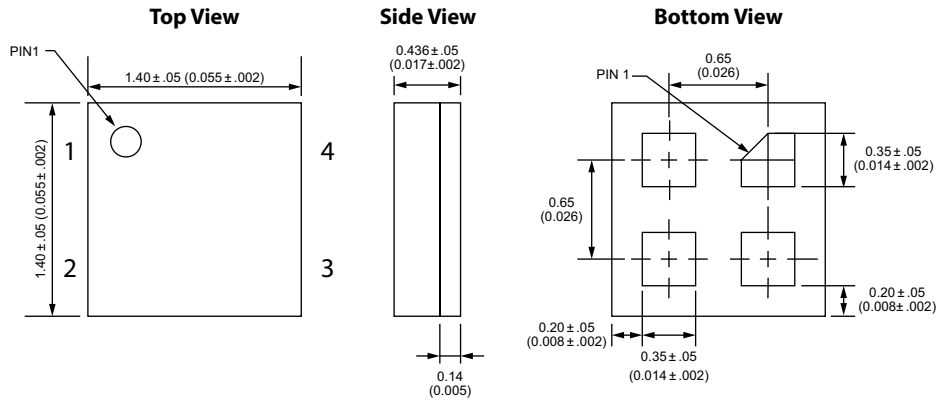

9 TMR Sensor Location

9.2 SOT Package

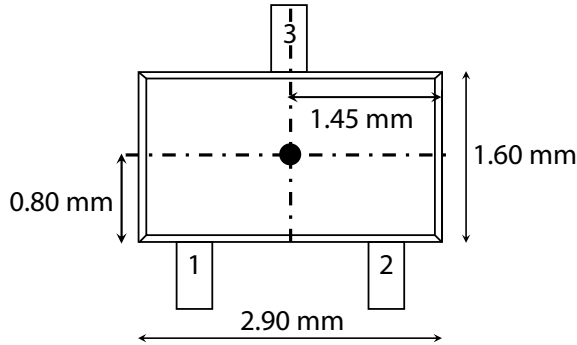

9.1 LGA Package

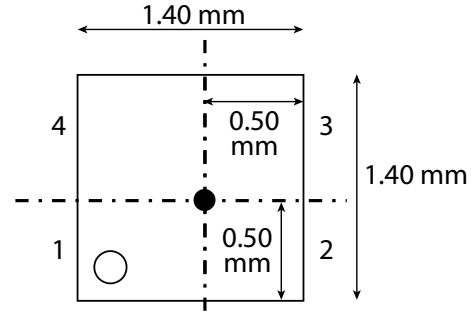

10 Magnetic Flux Response Diagram

10.1 Omnipolar Magnetic Flux Response

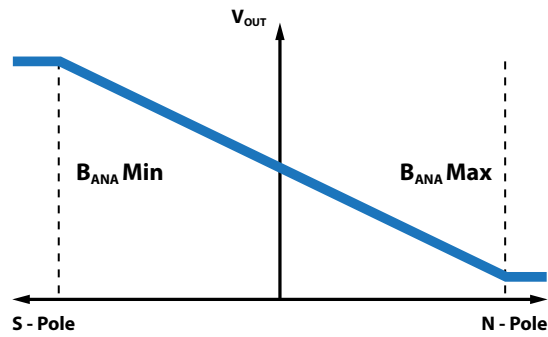

11 Suggested Pb-Free Reflow Profile

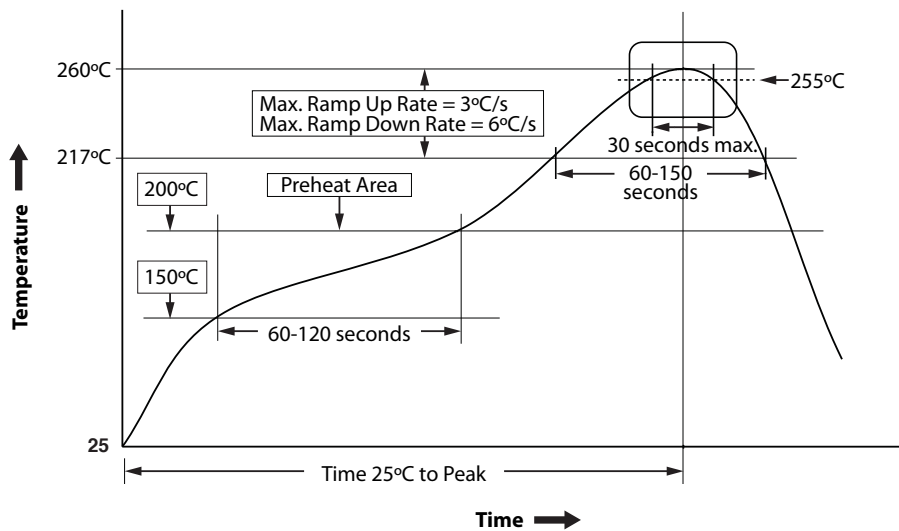

Notes:

1. Fully compatible with standard no-lead solder profile, 260 °C for 1 minute max (3 cycles max).
2. Profile shown as example. Users are advised to develop their own board-level profile.
3. Suggested Pb-free reflow profile derived from IPC/JEDEC J-STD-020E.
4. Temperature tolerance: +0 °C, as measured at any point on the package or leads
5. MSL rating of 1 (SOT-23-3 only) compatible with J-STD-020 or equivalent.
6. MSL rating of 3 (LGA-4 only) compatible with J-STD-020 or equivalent.
7. All temperatures refer to the center of the package, measured on the package body surface that is facing up during assembly reflow (e.g., live-bug). If parts are reflowed in other than the normal live bug assembly reflow orientation (i.e., dead-bug), Tp shall be within ± 2 °C of the live bug Tp and still meet the Tc requirements, otherwise, the profile shall be adjusted to achieve the latter. To accurately measure actual peak package body temperatures, refer to JEP140 for recommended thermocouple use.
8. Reflow profiles in this document are for classification/preconditioning and are not meant to specify board assembly profiles. Actual board assembly profiles should be developed based on specific process needs and board designs and should not exceed the parameters in this table.

12 TMR Sensor & Switch Packaging

12.1 SOT-23-3 Tape & Reel Packaging

Standard packaging is Tape & Reel containing 3,000 pieces. MSL Rating is 1.

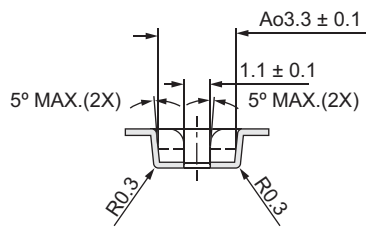
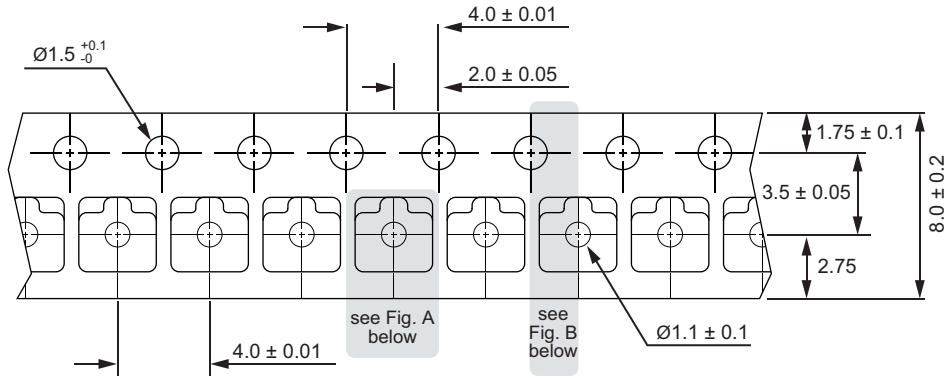

Fig. A

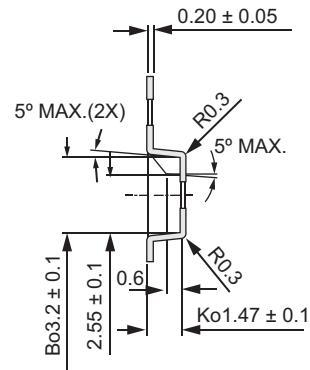
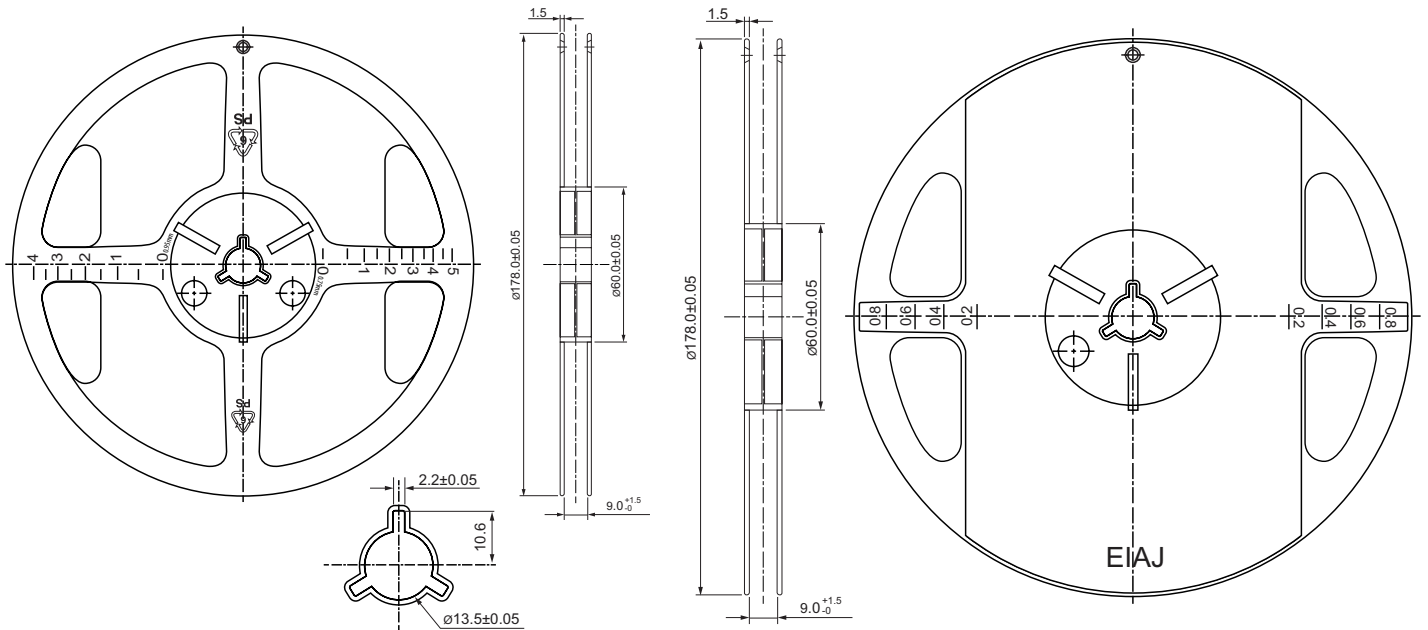

Fig. B



12 TMR Sensor & Switch Packaging

12.2 LGA-4 Tape & Reel Packaging

Standard packaging is Tape & Reel containing 3,000 pieces. MSL Rating is 1.

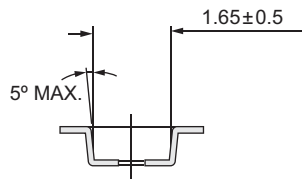
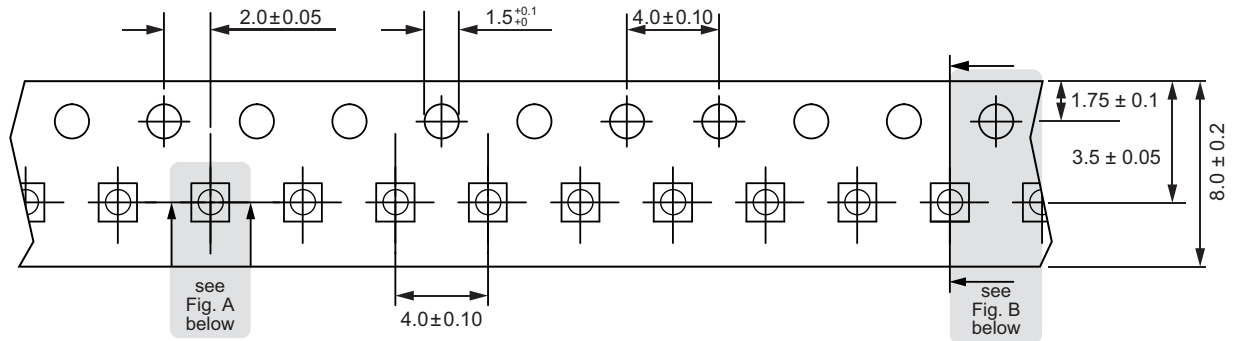

Fig. A

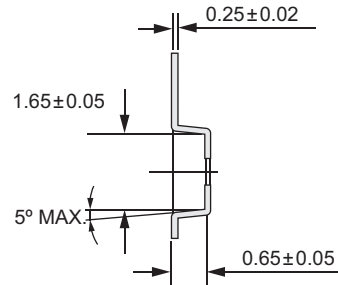

Fig. B

