

Series MIN830

Miniature Compression Load Cell



Select ranges in stock.

Shown Actual Size



Description

The Series MIN830 load cells are compact-sized for general purpose compression load applications. Constructed of all welded stainless steel, these bonded foil strain gaged force sensors provide reliable performance for demanding applications. Each MIN830 force sensor has a machined load button which is an integral part of the sensing element. The larger diameter units are available with internal signal conditioning for analog (0-5 Vdc, 0-10 Vdc, 4-20 mA) and/or digital (RS232, RS485, CANbus, MODbus) outputs. The MIN830 can be ordered with an optional ground stainless steel mounting base kit that can help reduce error or simplify mounting. Features include shock and vibration protection. Each unit is shipped with a 5 point calibration record traceable to NIST as standard.

Standard Features

- 0.50% Accuracy
- Ranges from 10 lbs. to 30,000 lbs.
- Compact Compression Design
- 2 mV/V nominal
- All Welded Stainless Steel
- -65°F to 250°F Operating Temperature
- Shock and Vibration Resistant
- 5 Point Calibration Record Traceable to NIST

Optional Features

- Metric Versions
- Internal Electronics for Analog or Digital Output (Consult factory for available ranges)
- Special Calibration
- Customer Specified Cable Lengths
- -65°F to +400°F Operating Temperature
- Mounting Base Kit
- Special Full Scale Ranges

Performance

Standard Ranges

10 to 30,000 lbs.
(Ranges in Bold Type are available in stock)
(See table).

Output

2mV/V nominal.

Accuracy

0.50% BFSL.

Temperature Effect on Zero

0.005% FSO/°F.

Temperature Effect on Span

0.005% Reading/°F.

Zero Balance

3% FSO.

Environmental Characteristics

Operating Temperature Range

-65°F to 250°F.
(-65°F to 400°F optional.)

Compensated Temperature Range

70°F to 170°F.
(-65°F to 400°F optional.)

MIN830

Series MIN830 Specifications

Baseline Configuration Specs Represented.
Modifications Encouraged - See Below
Custom Designs Available

Dimensions (inches)

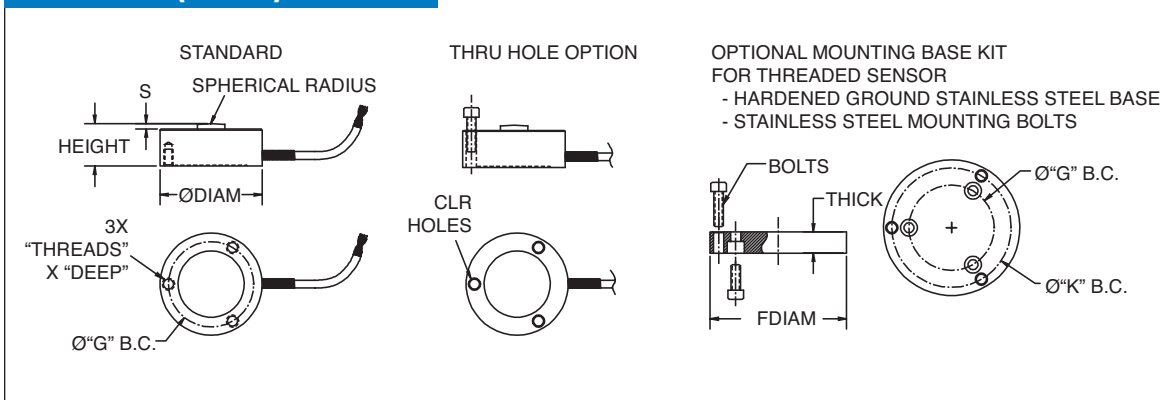

Load Cell Dimensions (Inches)

Capacities (LB)	Diameter	Height	Threads	X	G	S	Optional CLR
10, 25 , 50, 100	Ø1.00	0.62	4-40	0.22	0.75	0.05	N/A
250, 500 , 1000 , 2000	Ø1.25	0.39	6-32	0.21	1.00	0.07	#6
2500, 5000 , 7500, 10,000	Ø1.50	0.63	6-32	0.25	1.25	0.08	#6
15,000, 20,000 , 30,000	Ø2.00	1.00	6-32	0.25	1.63	0.12	#6

(Ranges in Bold Type are available in stock)

Flange Mount Base Dimensions (Inches)

Load Cell Diameter	F Diam	Thick	Bolts	"K" B.C.	"G" B.C.
Ø1.00	Ø1.50	0.32	6-32 UNF X 0.63	Ø1.25	Ø0.75
Ø1.25	Ø1.75	0.32	6-32 UNF X 0.63	Ø1.50	Ø1.00
Ø1.50	Ø2.00	0.32	6-32 UNF X 0.63	Ø1.75	Ø1.25
Ø2.00	Ø2.50	0.32	6-32 UNF X 0.63	Ø2.25	Ø1.63

Mechanical Characteristics

Static Overload Without Damage

150% FSO.

Calibration

Standard calibration is 5 pts (0, 50%, 100%, 50%, 0) compression.

Material

Welded stainless steel.

Electrical Characteristics

Bridge Resistance

350 or 700 Ohms nominal.

Excitation

10 Vdc or Vac.

Insulation Resistance

Greater than 5000 megaohms at 50 Vdc.

Electrical Termination

10', 4 Conductor Shielded Teflon Cable.

Balance resistor may be installed in cable near leads.

Electrical Characteristics

Connector Pins (Standard)

RED +EXE GREEN - SIG
BLACK - EXE WHITE +SIG

Customer specified wiring codes are available.



Modifications and Warranty

MODIFICATIONS: We realize transducer applications vary greatly and as such our designs are flexible. Choice of pressure port, electrical termination, material compatibility and performance characteristics are a few of the many options available. Specifications on this datasheet represent the standard configuration only. Product and company names listed are trademarks of their respective companies. Specifications subject to change without notice.

WARRANTY: Stellar Technology warrants that its product shall be free from defective workmanship and/or material for a twelve month period from the date of shipment, provided that Stellar Technology's obligation hereunder shall be limited to correcting any defective material FOB our factory. No allowance will be made for any expenses incurred for correcting any defective workmanship and/or material without written consent by Stellar Technology. This warranty is in lieu of all other warranties expressed or implied.