



LP Series - Analog is a surface mountable pressure sensor package with a compensated analog output suitable for ultra-low pressure sensing applications.

COMPANY: Merit Sensor is a leader in piezoresistive pressure sensing and partners with clients to create high performing solutions for a variety of applications and industries.

SENTIUM: Merit Sensor products incorporate a proprietary Sentium® technology developed to provide a best-in-class operating temperature range (-40°C to 85°C) and superior stability.

TECHNOLOGY: Merit Sensor utilizes a piezoresistive Wheatstone bridge in a design that anodically bonds glass to a chemically etched silicon diaphragm. All products are RoHS compliant.

CAPABILITIES: Merit Sensor designs, engineers, fabricates, dices, assembles, tests and sells die and packaged products from a state-of-the-art facility near Salt Lake City, Utah

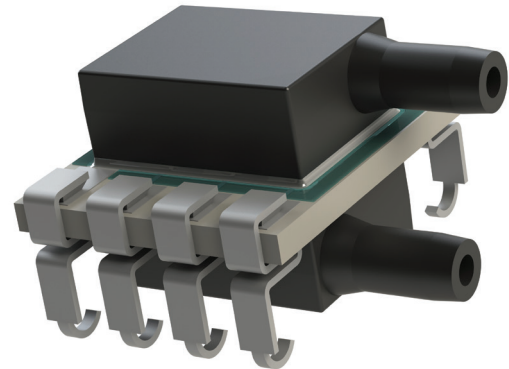

FEATURES

Pressure Range	0.15 to 1 psi (10.3 to 68.9 mbar; 1.03 to 6.89 KPa; 4.2 to 27.7 in H ₂ O)
Output	Amplified Analog
Type	Gage and Differential
Media	Clean, Dry Air and Non-corrosive Gases
Packaging	Tape and Reel
Customization	Supply Voltage, Temperature Calibration Range, Output Range, Accuracy Specification, Update Rate, etc.

BENEFITS

Performance	Enjoy best-in-class performance due to Merit's proprietary Sentium technology
Cost	Save money over time with high-performing die
Security	Feel confident doing business with an experienced company backed by a solid parent company (NASDAQ: MMSI)
Speed	Get to market quickly with creative and flexible solutions
Service	Experience prompt, personal and professional support

1410 Family Part Number Configurator

1410-XXX X -XX-XX

<p>Pressure</p> <p>P15 = .15psi </p> <p>P30 = .30psi </p> <p>1P0 = 1.0psi </p>	<p>Reference</p> <p>D = Differential </p> <p>G = Gage </p>	<p>Pin Type</p> <p>1 = J-lead</p>
<p>Supply Voltage</p> <p>1 = 5.0V </p>	<p>Port</p> <p>1 = Dual horizontal, facing same direction</p>	
<p>Output Range</p> <p>2 = 0.5V to 4.5V </p>		

SPECIFICATIONS

Parameter	Minimum	Typical	Maximum	Units	Notes
Electrical					
Supply Voltage (Vs)	2.7	5	5.5	V	
Supply Current	1.25	2	2.4	mA	(1)
Output Current			1.9	mA	
Min Output Load Resistance	5			kΩ	(2)
Operating Temperature	-40		85	°C	
Storage Temperature	-55		100	°C	
Performance					
DAC Resolution			12	Bit	
Ratiometric Output Range (Vout)	0	10 to 90	100	%Vs	(1)
Accuracy	-1.5		1.5	%FS	(3) (4)
Lifetime Drift	-0.5		0.5	%FS	
Startup Time			8	ms	
Analog Update Time		25		ms	
Proof Pressure	5X				(5)
Burst Pressure	10psi				

Notes:

- (1) @ 5V input voltage
- (2) Must be added at the point of use
- (3) Over 0°C to 60°C
- (4) Applicable if Vs = 4.75V to 5.25V
- (5) Full scale pressure

Transfer Function Formula

$$P_{psi} = (P_{max} - P_{min}) \cdot \left(\frac{V_{out} - V_{min}}{V_{max} - V_{min}} \right) + P_{min}$$

Where

- P_{psi} = Measured Pressure in PSI
- P_{Max} = Maximum Pressure
- P_{Min} = Minimum Pressure
- V_{min} = Minimum Volatage (Usually 0.5V)
- V_{max} = Maximum Volatage (Usually 4.5V)
- V_{out} = Output voltage (pin 6)

Media Compatibility

For Use With Non-corrosive Dry Gasses
Solder temperature: max 250 °C, 5 seconds max

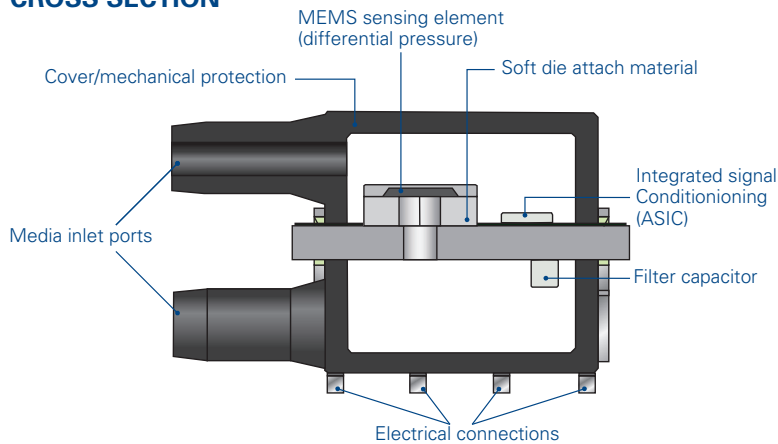
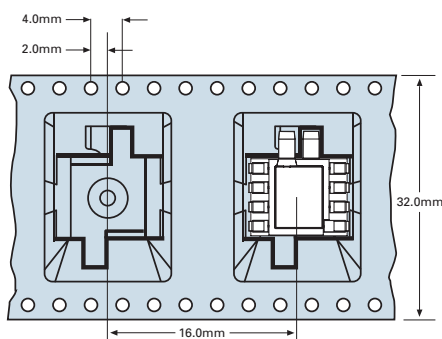
CROSS SECTION

PACKAGING AND SHIPPING

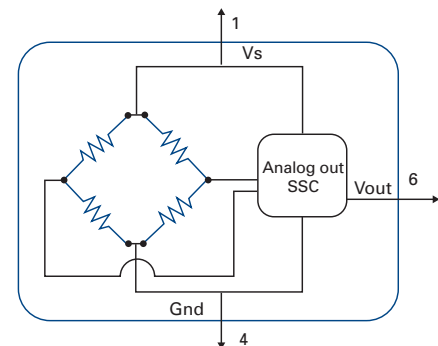
ELECTRICAL

Note: Power supply decoupling and output filtering included



DIMENSIONS FOR STANDARD OPTIONS (in millimeters)

Dimensions for reference only. Engineering drawings (with tolerance) available upon order.

Device Pinout
P1 = Vs

P2 = N/C

P3 = N/C

P4 = Ground

P5 = N/C

P6 = Vout

P7 = N/C

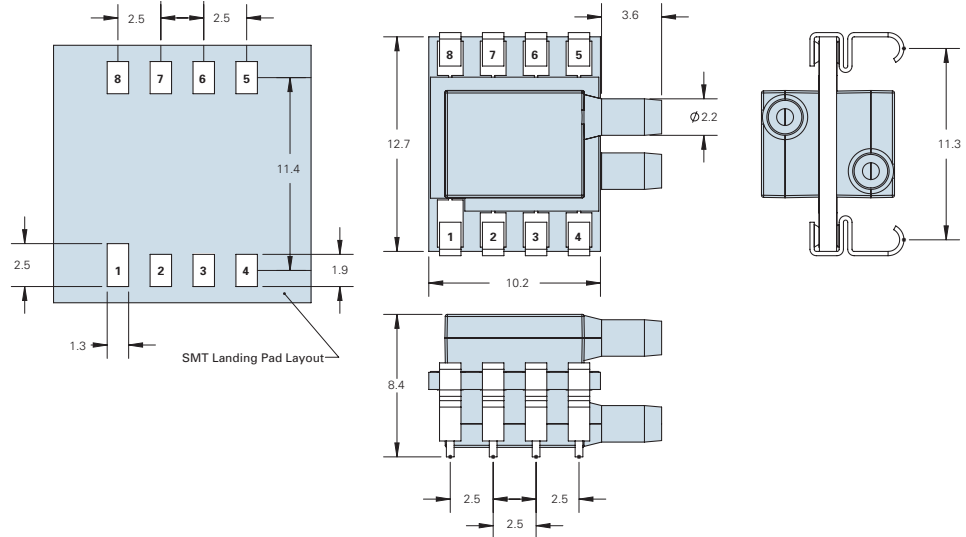
P8 = N/C

Example 1: 0.0 to 0.15 PSI Gage 0-60°C

Part: 1410-P15G-12-11

 $P_{min} = 0.0 \text{ psi}$, $P_{max} = 0.15 \text{ psi}$
 $V_{out} = 2.5 \text{ V}$
 $V_{minCompV} = 0.5 \text{ V}$, $V_{maxCompV} = 4.5 \text{ V}$

$$P_{psi} = (P_{max} - P_{min}) \cdot \left(\frac{V_{out} - V_{min}}{V_{max} - V_{min}} \right) + P_{min}$$

$$PSI = (0.15 - 0.0) \cdot \left(\frac{2.5 - 0.5}{4.5 - 0.5} \right) + 0$$

 $PSI = .075$

Part: 1410-P15G-12-11

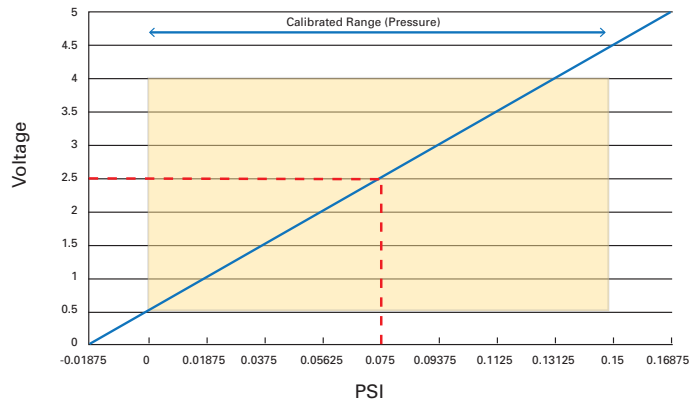
Example 2: -0.15 to 0.15 PSI Differential 0-60°C

Part: 1410-P15D-12-11

 $P_{min} = -0.15 \text{ psi}$, $P_{max} = 0.15 \text{ psi}$
 $V_{out} = 3.25 \text{ V}$
 $V_{minCompV} = 0.5 \text{ V}$, $V_{maxCompV} = 4.5 \text{ V}$

$$P_{psi} = (P_{max} - P_{min}) \cdot \left(\frac{V_{out} - V_{min}}{V_{max} - V_{min}} \right) + P_{min}$$

$$PSI = (0.15 - (-0.15)) \cdot \left(\frac{3.25 - 0.5}{4.5 - 0.5} \right) + (-0.15)$$

 $PSI = .05625$

Part: 1410-P15D-12-11

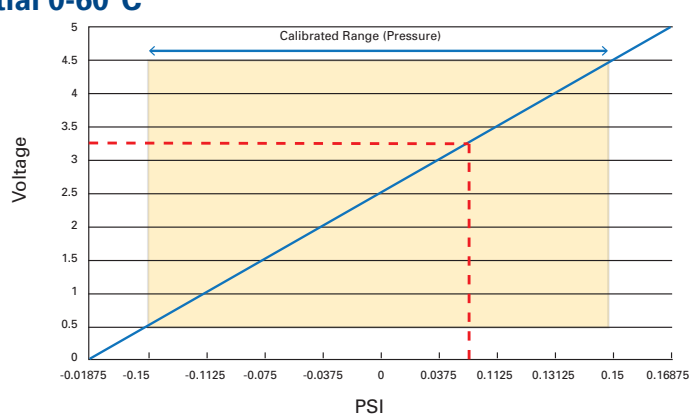



Merit Sensor is based in Salt Lake City, Utah

